

CAM-130-10

Svolge Controls and operates a genset, connecting the power user to the generator.

USER MANUAL

Functions:



Complete with backlit graphic display to view:

- Three generator voltmeters.
- Three generator ammeters.
- Generator frequency meter.
- Generator tachometer.
- Generator kW (active), kVAR (reactive) and kVA (apparent) powers.
- Battery voltmeter.
- Fuel level gauge.
- Engine temperature.
- Oil pressure.
- Total hour-meter.
- Partial hour-meter.
- Start-ups counter.

- Automatic monitoring of faults with display messages.
- Complete three-phase voltmetric control of genset (undervoltage, overvoltage, phase asymmetry, incorrect phase sequence, underfrequency and overfrequency).
- Texts in 7 languages: Italian, English, French, German, Spanish, Portuguese and a programmable language.
- CAN Bus Connection SAEJ1939.
- RS232, RS485 serial ports and USB.
- MOD Bus RTU Protocol.
- 4-maintenance management.
- Management of rental hours.
- Starting remote control.
- Ability to start generator when the battery charge is low.
- Option of associating inputs and outputs with different functions.
- Glow plug preheating management.
- Clock for programming genset starting or stopping.
- Automatic test.
- Fault log.
- Option of password protected programming.
- Dimensions (LxHxW) 157x109x74mm



Tel. +39 0521/772021

E-mail: info@elcos.it – <https://www.elcos.it>



CONTENTS

INDEPENDENT GENERATING SET CONTROL UNIT	1
CONTENTS	2
CHRONOLOGY OF MANUAL REVISIONS.....	3
INSTRUCTIONS IN BRIEF	4
INSTRUMENTS	4
DISPLAY.....	5
OPERATION.....	6
FUNCTION SELECTION	6
MANUAL	6
AUTOMATIC	6
OFF	6
PROGRAMMABLE OUTPUTS	6
GLOW PLUG PREHEATING	6
ENGINE TYPES	7
AUTOMATIC TEST	7
ENGINE RUNNING DETECTION	7
STOPPING SYSTEMS	7
EMERGENCY STOP	7
GENERAL ALARM	7
GENSET AND USER PROTECTIONS	8
PREVENTIVE MAINTENANCE	8
RENTAL FUNCTION	8
STARTING GENSET WITH LOW BATTERY	8
DAILY STARTING-STOPPING	8
REMOTE START INPUT (TERMINAL 30)	8
STOP INPUT (TERMINAL 33)	8
PROGRAMMABLE INPUTS (TERMINALS 32, 33, 41, 42, 47)	8
KEY INPUT (TERMINAL 45)	9
CAN BUS INSTRUMENTS AND MESSAGES	9
ENGINE WARM-UP	9
VOLTMETRIC CONNECTIONS	9
GENERATOR VOLTMETRIC RELAY	10
IMMINENT START WARNING	10
PASSWORD	10
SERIAL NUMBER (ID)	10
SERIAL PORT	10
DIAGRAM FOR MECHANICAL MOTORS	11
DIAGRAM FOR ELECTRONIC MOTORS	12
DIAGRAM FOR MECHANICAL MOTORS WITH PERMANENT MAGNETS ALTERNATOR	13
USER PROGRAMMING	15
PROGRAMMING A NUMERICAL PARAMETER.....	15
ENABLING/DISABLING A PARAMETER	16
PROGRAMMING A NUMBER	16
REPLACING THE CONTROL UNIT.....	17
RESTORE FACTORY SETTINGS	17
ACCESSING TECHNICAL PROGRAMMING	17
TEXT STRING SETTINGS.....	18
TECHNICAL PROGRAMMING	18
LANGUAGE CHOICE	18
CLOCK/CALENDAR	18
CURRENT TRANSFORMERS (A.T.)	18
VOLTAGE TRANSFORMERS (V.T.).....	19
MOTOR RUNNING	19
GENERAL FUNCTIONS	19
ENGINE	20
CAN BUS SAE J1939	22
GENERATOR	23
AUTOMATIC TEST	24
CHOICE OF TRANSMITTERS.....	25
MAINTENANCE AND RENTAL	26
RESETTING	27

SWITCHING OFF FUNCTIONS	27
STAND BY	27
FAULT LOG	28
COMMUNICATION PORTS	28
EXPANSIONS	28
PROGRAMMABLE INPUTS.....	29
PROGRAMMABLE OUTPUTS	30
DEVICE	31
PASSWORD	31
FAULT LIST	33
TECHNICAL SPECIFICATIONS.....	34
WARNING	36
INFORMATION FOR ORDERING	37
STANDARD ACCESSORIES	37
ACCESSORIES AVAILABLE ON REQUEST	37
DOCUMENTATION ON REQUEST.....	37

CHRONOLOGY OF MANUAL REVISIONS

<i>Date</i>	<i>Revision</i>	<i>Description</i>	<i>Page</i>
10/12/2024	1.00	First release	
07/05/2025	1.01	REMOTE PANEL	12, 29, 38

INSTRUCTIONS IN BRIEF

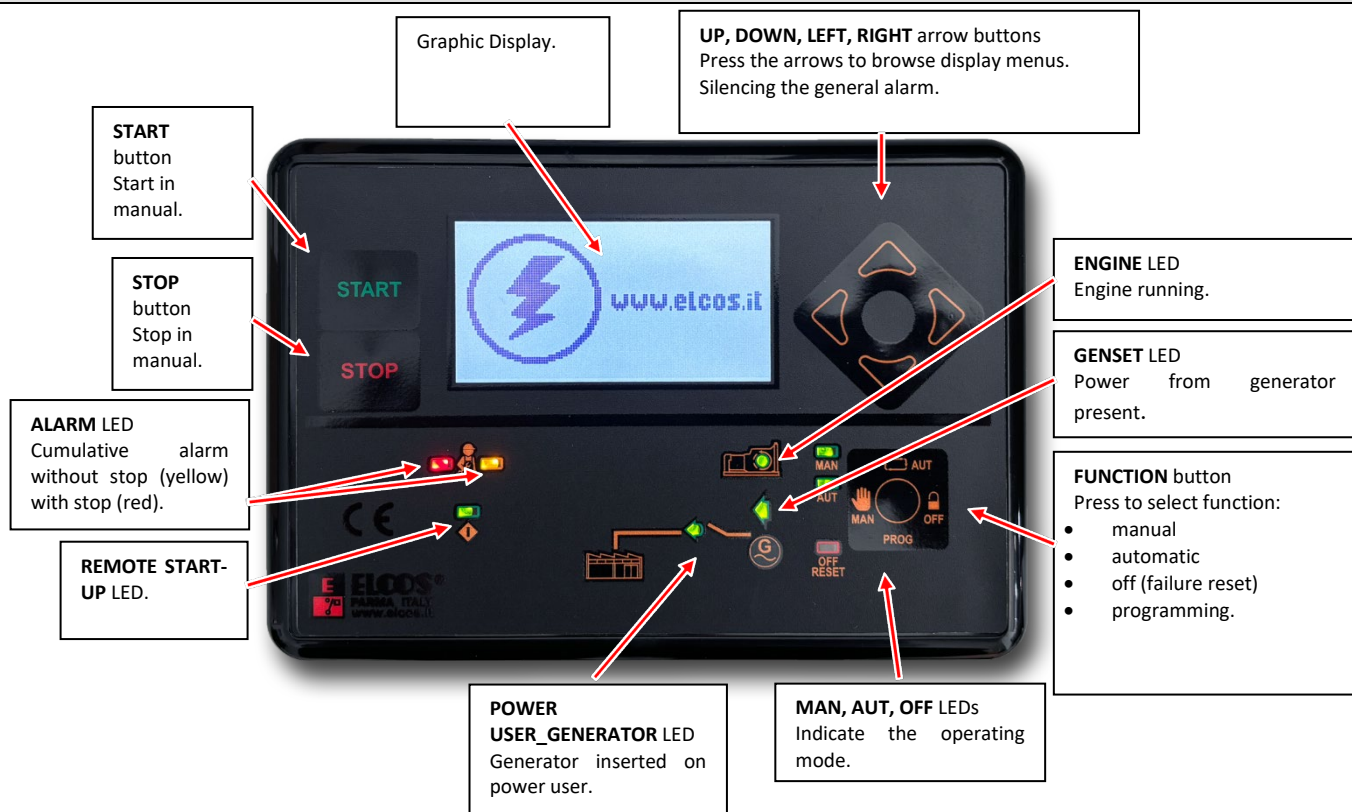

INSTRUMENTS

The control unit has a backlit 128 x 64 dot graphic display. It is used to view the following instruments:

- Three line-to-line generator voltages.
- Three star generator voltages.
- Three generator ammeters.
- Generator frequency meter.
- Active (kW), reactive (kVAR) and apparent (kVA) power. The powers are displayed for each phase and as a sum of the phases.
- Generator power factor indicator displayed for each phase.
- Generator energy counter (kWh).
- Battery voltage.
- D+ voltage (pre-excitation alternator).
- Fuel tank level indicator.
- Engine temperature expressed in °C or °F.
- Oil pressure expressed in BAR or kPa.
- Engine revolutions (RPM).
- Total hour-meter.
- Partial hour-meter.
- Start-ups counter.
- Starting failure counter.
- Maintenance expirations.
- Rental hours expirations.
- Calendar clock.
- Automatic test.

All the electrical instruments (V, A, Hz and kW) are also displayed simultaneously. Simply pressing the arrows displays all the instruments for the engine. In the event of a fault, the display presents the message indicating the fault that has occurred.

DISPLAY

The instruments displayed on the control unit are divided into groups. The groups are:

- Generator
- Engine instruments
- CAN Bus instruments (if CAN Bus connection is enabled)
- Counters
- Maintenance (if maintenance hours have been set)
- Rental (if rental hours have been set)
- Fuel top-up management (if function is enabled)
- Faults
- Clock
- Information about the control unit.

The two **UP** and **DOWN** arrows are used to scroll through the instrument groups on the display or to select the sub-menus under the settings.

The following are a few examples of instrument display menus.

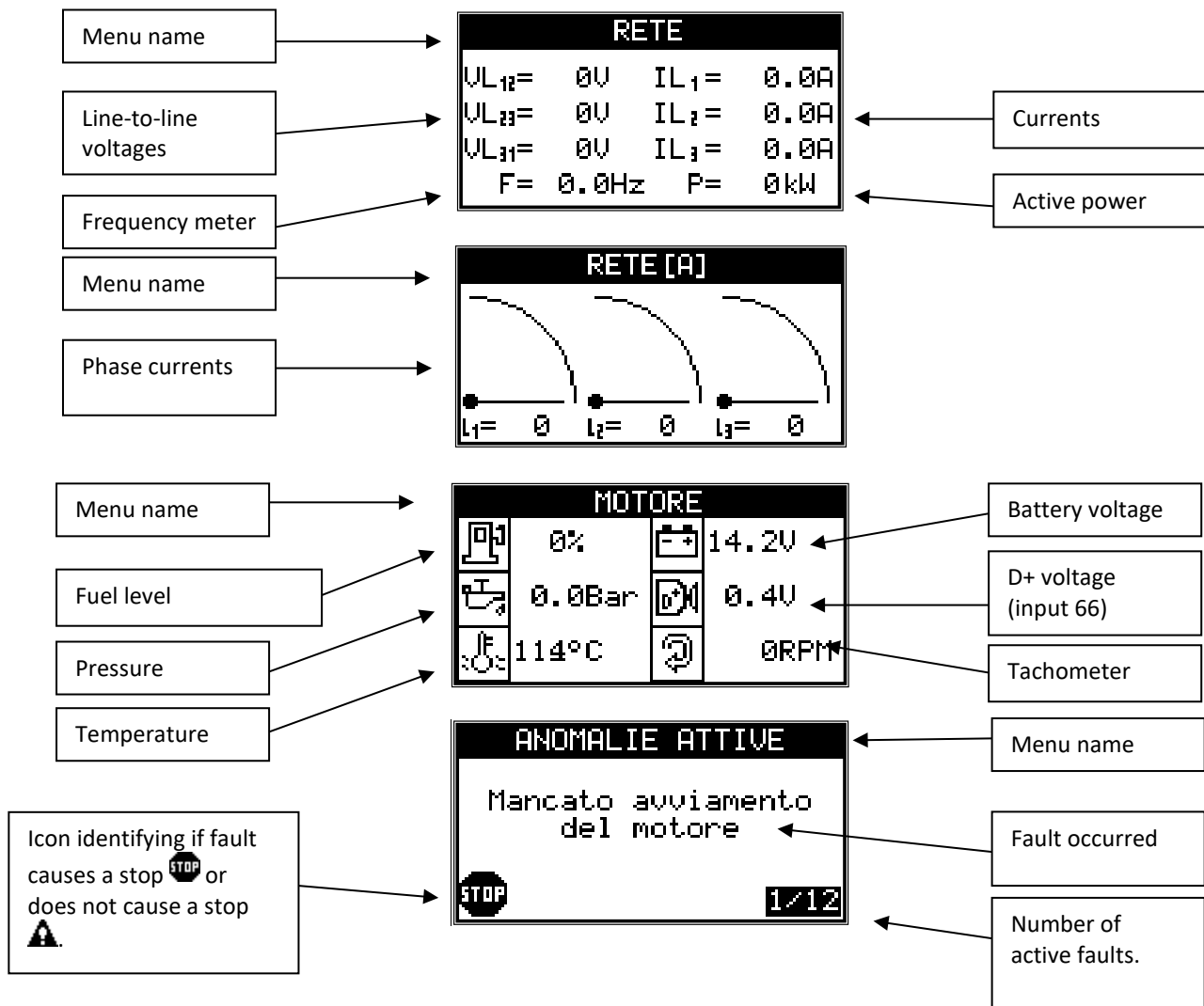

OPERATION

FUNCTION SELECTION

FUNCTION button.

The function selected using the button is indicated by the corresponding light turning on.

MANUAL



Image displayed when switched to manual.

Press **START** to start the unit and **STOP** to stop it (a quick press is sufficient).

In manual mode, the generator protection function can be programmed in two ways:

- Display the fault recorded and stop the engine (this is the default setting).
- Only display the fault recorded, without stopping the engine. Generator overspeed and emergency faults are programmed to shut down the engine; they cannot be programmed without engine shutdown.

AUTOMATIC



Image displayed when switched to automatic.

When the remote start contact is closed and after the **START DELAY FOLLOWING THE CLOSURE OF THE CALL**, the control unit starts the genset.

With the engine running and with correct generator voltage and frequency, once the **G.S. VOLTAGE PRESENT DELAY** has elapsed, the generator contactor is closed. When operating, the genset is protected from any faults.

When the remote start contact is open and after the **DELAY FOLLOWING THE OPENING OF THE CALL**, the control unit commands the generator contactor to open.

The **COOLING TIME** enables and facilitates subsequent engine cooling before it shuts down.

To facilitate start-up, a special circuit determines a series of start-up attempts, the number, pause duration and start-up duration of which can be programmed. If running of the entire series of start-up attempts is unable to start the engine, when the cycle is completed, **STARTING FAILURE** is displayed and the stop cycle starts.

OFF



Image displayed when switched to off. When set to OFF, the engine cannot be started in any way and, if it is running, it stops without the engine cooling step.

PROGRAMMABLE OUTPUTS

WARNING!

Outputs 6, 19 and 70 can be associated to many functions (see programming section under the section "PROGRAMMABLE OUTPUTS"). **It is NOT possible to simultaneously associate more than one function to an output.** By default, management of glow plugs is associated to output 6, the signal that simulates the 15/54 to output 19, and the general alarm to output 70.

GLOW PLUG PREHEATING

Activation of the glow plug output is adjustable — from a minimum of 0 seconds (command off) to a maximum of 60 seconds — for both automatic and manual mode. Once activation has been completed, the engine start-up procedure begins. Glow plug post-heating can also be managed, i.e. maintaining output live for a set amount of time, even after the engine has been started (see section on programming).

ENGINE TYPES

The control unit can manage start-up of both diesel and petrol engines. Diesel engines allow for the connection of the CAN bus line to the control units with electronic injection. For choice of engines, see the programming section.

AUTOMATIC TEST

The automatic test is enabled only with the control unit on automatic. During the test, the generator set starts up and stays running for the AUTOMATIC TEST DURATION time (programmed at 3 minutes). If remote start-up is requested, the generator contactor closes. The display shows AUTOMATIC TEST during the test cycle. You can also choose whether to run a commutation or not during the test (default setting: no commutation). Press STOP to stop the engine during the test. The test will not be run if there is a fault. The automatic test can be performed in two ways:

- WEEKLY: the test will be run weekly at the time and on the day set.
- MEASURED: The test can be programmed to run at cycles ranging from 1 to 30 days. The default setting is 7 days. To enable the test, just enter User Programming and include the function. Once any one of the test parameters has been set, it starts for the first time when one minute after quitting the setting mode has elapsed. If at that time the conditions for starting the test are not present (e.g. because the control unit is not on automatic), the test will be run at the next deadline. The time count starts all over again when the control unit is reset.

ENGINE RUNNING DETECTION

Engine running is detected by revealing the generator frequency and voltage and by detecting the voltage and frequency of the battery charger alternator (permanent or pre-excitation magnets). When an engine with electronic management is connected to the control unit, detection of the running engine occurs when the RPM read by the CAN Bus line exceed the RUNNING ENGINE THRESHOLD RPM. Once detected, the starter motor switches off and the green **ENGINE** LED lights up.

STOPPING SYSTEMS

Stopping can be achieved in two ways:

- With the electromagnet or solenoid valve energized when the engine is running and de-energized when the engine is stopped (default setting).
- With the electromagnet de-energized when engine is running and energized when it is stopped, remaining in this condition for the entire STOPPING TIME after engine not running has been detected.

If, after 120 seconds from receipt of the stop command, the control still detects the engine running signal, the STOPPING FAILURE trips.

EMERGENCY STOP

This is available in all operating modes. It is possible to install (hook mount) one or more buttons. Stopping is immediate, without engine cooling; it activates the general alarm and EMERGENCY STOP is displayed.





Do not use the emergency button in combination with a stopping system that is not energized while r

GENERAL ALARM

The general alarm can be obtained by installing a signaller at the appropriate alarm terminal. It can be programmed so that it is always on or remains on for a specific amount of time. It trips whenever the control unit detects a fault. Pressing one of the arrows silences the alarm.

GENSET AND USER PROTECTIONS

Tripping of a fault is shown on the display and can cause the engine to cut out and activates the general alarm. See the **FAULT LIST** table.

Normally the display shows the genset instruments; in the event of a fault, it displays the fault message triggered. If the fault causes a stop, the red LED flashes and the  icon lights up; if the fault does not cause a stop, the yellow LED flashes and the  icon lights up.

If the faults are detected by the CAN Bus line connected to the engine's electronic injection control unit, the yellow and red LEDs light up and remain steady on.

To review the instruments on the display and, at the same time, silence the general alarm, use one of the navigational arrows. After 20 seconds have elapsed since the last time the button was pressed, the display reverts back to displaying the fault or faults that have occurred.

When **OFF RESET** lights up, the faults can be reset by pressing the **FUNCTION** button. If the OFF function is disabled, press the **FUNCTION** button to reset the faults. **FUNZIONE**.

PREVENTIVE MAINTENANCE

When preventive maintenance operations are to be carried out, the **ALARM** LED will flash yellow and the maintenance number is displayed along with a previously set description. If programmed, stopping is also achieved with **PROTECTION IN MANUAL** bypassed and with the **PROTECTION INHIBITION** input active. The procedure for resetting expired maintenance is to be performed only by the genset manufacturer.

RENTAL FUNCTION

It is possible to program the number of genset rental hours; after this time has elapsed, the control unit can immediately block genset operation or can block it at the next start-up. If programmed, stopping is also achieved with **PROTECTION IN MANUAL** bypassed and with the **PROTECTION INHIBITION** input active. Rental hours are counted down when the engine is running.

STARTING GENSET WITH LOW BATTERY

When the battery is low, the genset can only be started up in automatic mode. When the voltage measured at the battery terminals is below the minimum threshold, the engine will start and remain running until the maximum threshold has been exceeded and the programmable delay time has elapsed.

DAILY STARTING-STOPPING

The functions managed by the control unit's internal clock are only active in automatic mode. Up to 10 genset starts can be programmed, with relative switching of the power user to the generator at certain daily time slots.

It is also possible to program a genset lockout at a certain daily time slot.

REMOTE START INPUT (TERMINAL 30)

The remote start input is active with the control unit in automatic mode. When the contact closes to ground, the generator starts up.

STOP INPUT (terminal 33)

The stop input is active with the control unit in automatic mode. When the contact closes to ground, **REMOTE STOP** is shown on the display. The control unit does not permit any start-up and, if the genset is running, it stops. Other functions can be associated to this input; see the programming section.

PROGRAMMABLE INPUTS (terminals 32, 33, 41, 42, 47)

Input 32, 33, 41, 42 and 47 are completely programmable (see the programming section). The following settings are possible: Function, Text, Intervention delay, Stop, Cooling, Storage, Polarity, Activation.

KEY INPUT (terminal 45)

The normally open contact of a key switch may be connected to input 45. The other pole of the contact should be connected to the battery's positive pole protected by a fuse. When the contact is closed, thus delivering positive voltage to the input, the control unit, if previously off, switches on, exiting low-power mode. When the contact is opened and the engine is off, the control unit turns off after a few seconds. However, if the engine is running, opening the contact does not stop the engine or shut off the control unit. Engine shutdown must follow the standard procedures described in earlier sections.

If using a switch to shut off the control unit is not desired, a direct positive voltage must be connected to the input; otherwise, the control unit will remain off.

CAN BUS INSTRUMENTS AND MESSAGES

Every message or instrument appearing on the display having to do with the injection control unit and read by the CAN Bus line can be identified by the characters [ECU] shown in the lower right corner.

- Fault messages are shown on the display as SPN, FMI and OC: SPN is a number identifying a particular component of the diesel engine; FMI is a number identifying the failure or malfunction of the SPN component; OC identifies the number of times this particular problem occurred in the engine.
- If the CAN Bus line connection between the two control units is interrupted, the message CAN Bus fault will appear. The instruments managed and displayed by the control unit are:

<i>Instrument</i>	<i>Description</i>	<i>U.M.</i>	
Tachometer	Engine revolutions.	RPM	
Oil pressure	Engine oil pressure.	BAR	kPa
Engine temperature	Engine water or oil temperature.	°C	°F
Fuel consumption	Amount of fuel consumed by the engine per unit of time.	l/h	
Fuel temperature	Fuel temperature at injector inlet.	°C	°F
Turbo temperature	Temperature of turbo compressor oil.	°C	°F
Oil temperature	Temperature of engine oil.	°C	°F
Intercooler temperature	Temperature of fluid in the intercooler downstream of the turbo compressor.	°C	°F
Intake temperature	Temperature of pre-combustion air.	°C	°F
Coolant level	Coolant level.	%	
Fuel pressure	Pressure of the fuel between the fuel pump and the injection pump.	BAR	kPa
Coolant pressure	Pressure of coolant in the cooling system.	BAR	kPa
Engine torque	Engine output torque percentage.	Nm	
Engine power	Power developed by the engine.	kW	
Fuel level	Indicates fuel level	%	
Oil level	Level of oil in the engine.	%	

Electronic engines currently managed are: John Deere, Perkins, Scania, Volvo, Deutz, FPT, VM, Cummins and MTU.

ENGINE WARM-UP

Function can be activated in SCANIA engines with CAN Bus connection. It warms up the engine at idling speed after it starts. The function takes both engine temperature and set time into account. When the engine reaches the set temperature or set time, the control unit speeds up the engine to rated speed. This default function is disabled. See the programming section for instructions on how to set the temperature threshold and time. Heating can also be managed for mechanical engines by activating the function in a programmable output and connecting an electromagnet to the engine.

VOLTMETRIC CONNECTIONS

The control unit can be configured to manage THREE-PHASE, TWO-PHASE and SINGLE-PHASE voltages. If the generator power is three-phase, the phases must be connected to terminals 96, 97 and 98 and the neutral to terminal 95. With two-phase connection, terminals 96 and 97 must be connected and the neutral must not be connected. Instead, with the single-phase connection, the phase must be connected to terminal 97 and the neutral to terminal 95.

GENERATOR VOLTMETRIC RELAY

The generator's voltmeter relay is located inside the control unit and serves to control the genset voltage and frequency. The parameters considered are: power failure, undervoltage, overvoltage, asymmetrical voltages, incorrect phase sequence, under-frequency and overfrequency.

- Generator voltmeter relay: when each parameter has been accepted individually, after the generator voltage present delay has elapsed (programmed to 7 seconds), the generator contactor closes. It takes just one parameter outside the normal range to de-energize the generator contactor.

IMMINENT START WARNING

Every automatic start-up is preceded by the intermittent activation of the general alarm output for 8 seconds; then, 3 seconds later, the start-up cycle begins. If a buzzer is connected to this output, the operator is notified that start-up is imminent. This function can be bypassed. Warning: the output can be associated to other functions; see the programming section.

PASSWORD

Access to technical settings is password activated. There are 7 password levels, each level gives access to different settings. The default password settings are all "0000" and it is possible to enter the settings without entering any other codes, except for level 7. To change the codes and activate the passwords, see the programming section. The list of the 7 levels is given below:

1. The operator can read all the settings but cannot edit them.
2. Access in editing mode to rental hours and history log from maintenance hours.
3. Access only for resetting expired maintenance.
4. Access only for resetting expired rental blocks and for GSM block.
5. The operator can read and edit all settings.
6. Access in editing mode to total operating hours.
7. Access to the device menu.

For example: if we wish to prevent the operator from modifying the total operating hours, we must set a different password to "0000" in level 6, for example "1234". Doing this, we can enter the technical settings using the default password ("0000"), but will not have access to the operating hours. To access the operating hours menu we must enter the password "1234".

SERIAL NUMBER (ID)

It is possible to program an alphanumeric serial code in the control unit. This number is displayed every time the control unit is switched on; it can be read in the INFORMATION menu or by pressing the left arrow for 4 seconds. Refer to the programming section.

SERIAL PORT

The control unit has 4 serial ports: RS232, RS485, USB 2.0 and CAN Bus.

- RS232: used to connect the control unit:
 1. to a personal computer, for setting parameters with the ZW-SMART software
 2. to a personal computer for the ZW-100 remote operation software
 3. to Ethernet interface with the ZW-100 remote operation software
 4. to GSM modem for text message management.
- RS485: used to communicate with:
 1. input/output expansion modules
 2. the remote panel
 3. this port can be used in slave mode so that an external device can poll the control unit using the MOD Bus RTU protocol.
- USB 2.0: used to connect the control unit:
 1. to a personal computer, for setting parameters with the ZW-SMART software
 2. to a personal computer for the ZW-100 remote operation software.
- CAN Bus: used to connect the control unit to the CAN Bus line of electronic engines with SAE J1939 protocol.

WIRING DIAGRAM

DIAGRAM FOR MECHANICAL MOTORS

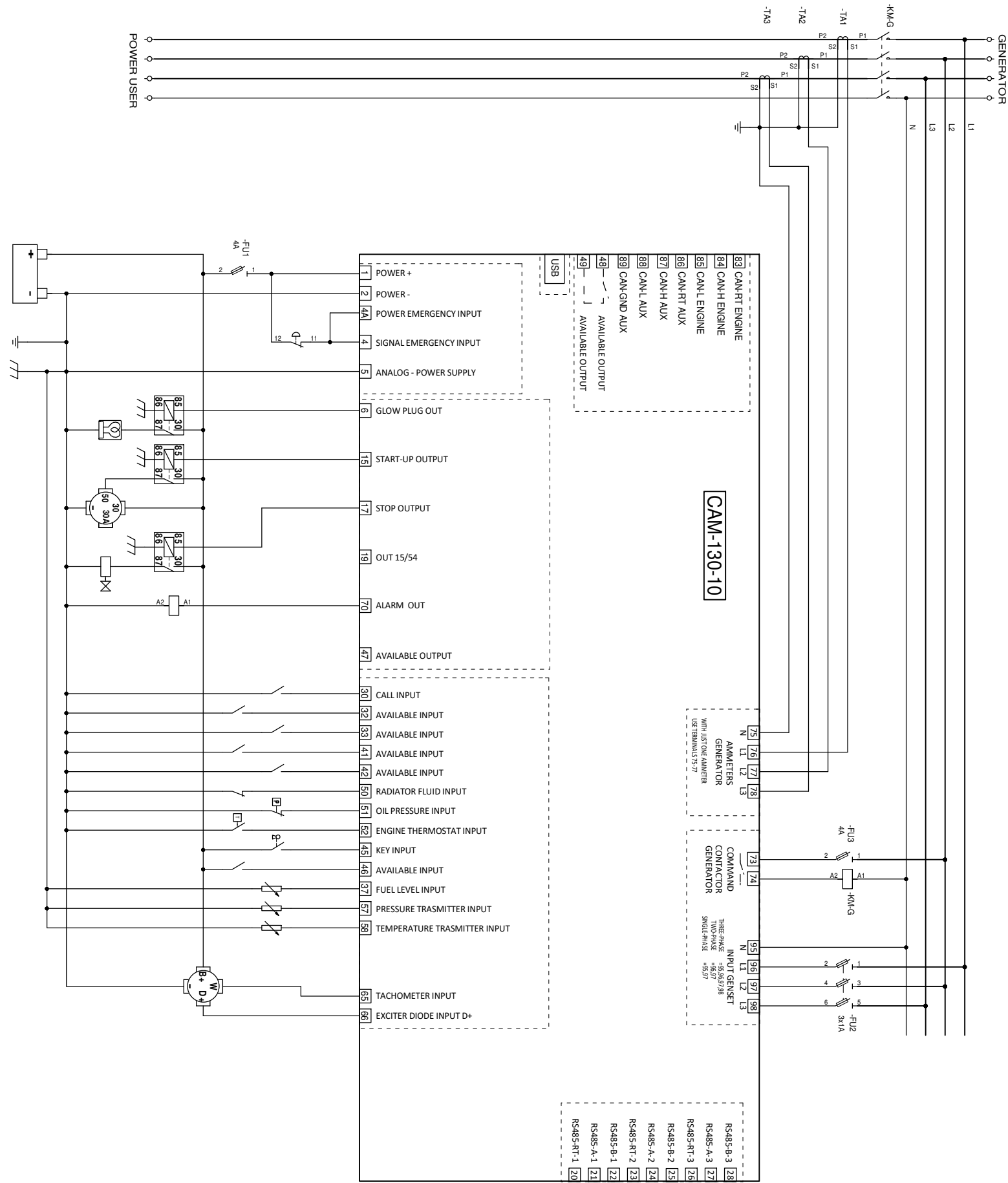

WIRING DIAGRAM

DIAGRAM FOR ELECTRONIC MOTORS

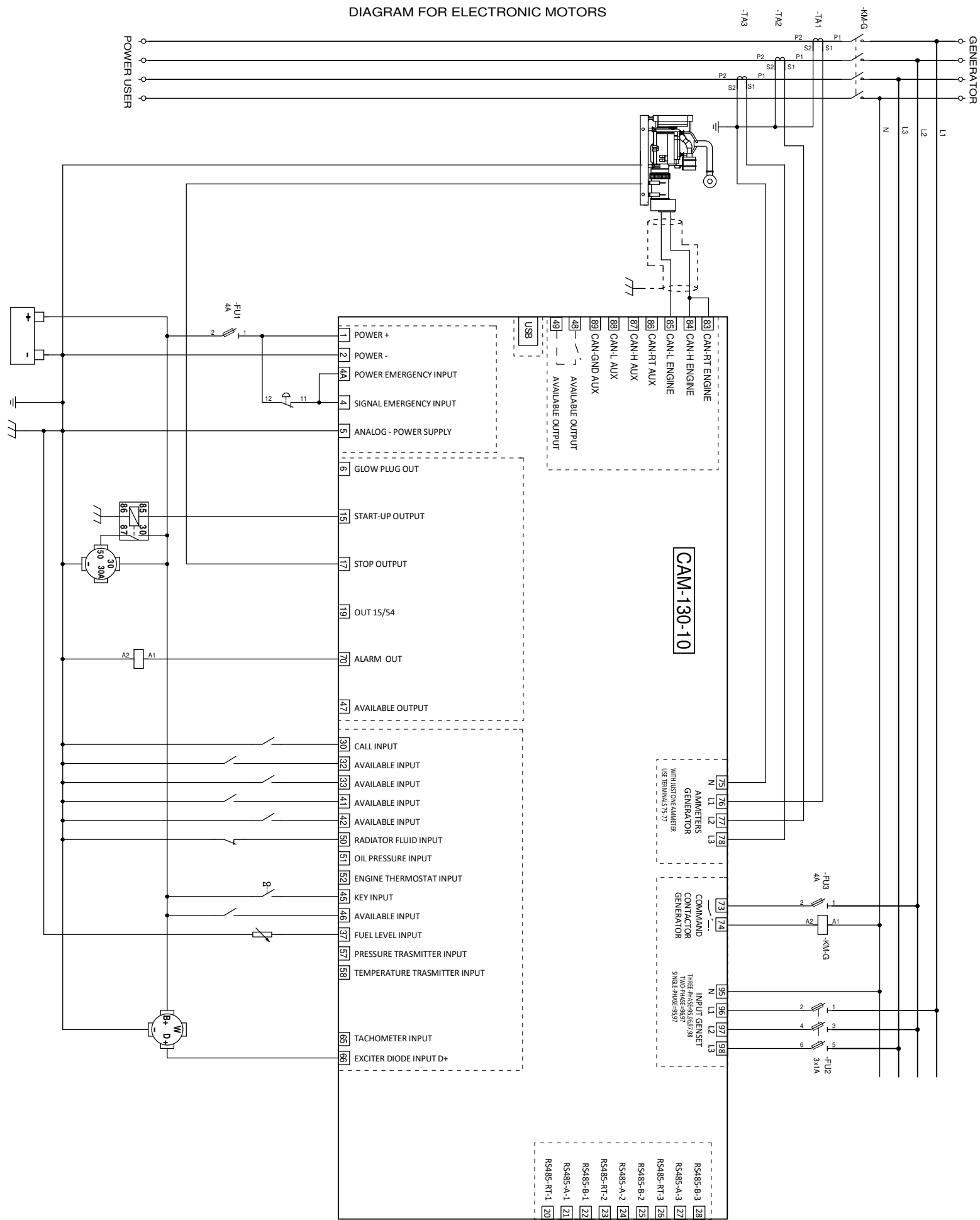

WIRING DIAGRAM

DIAGRAM FOR MECHANICAL MOTORS WITH PERMANENT MAGNETS ALTERNATOR

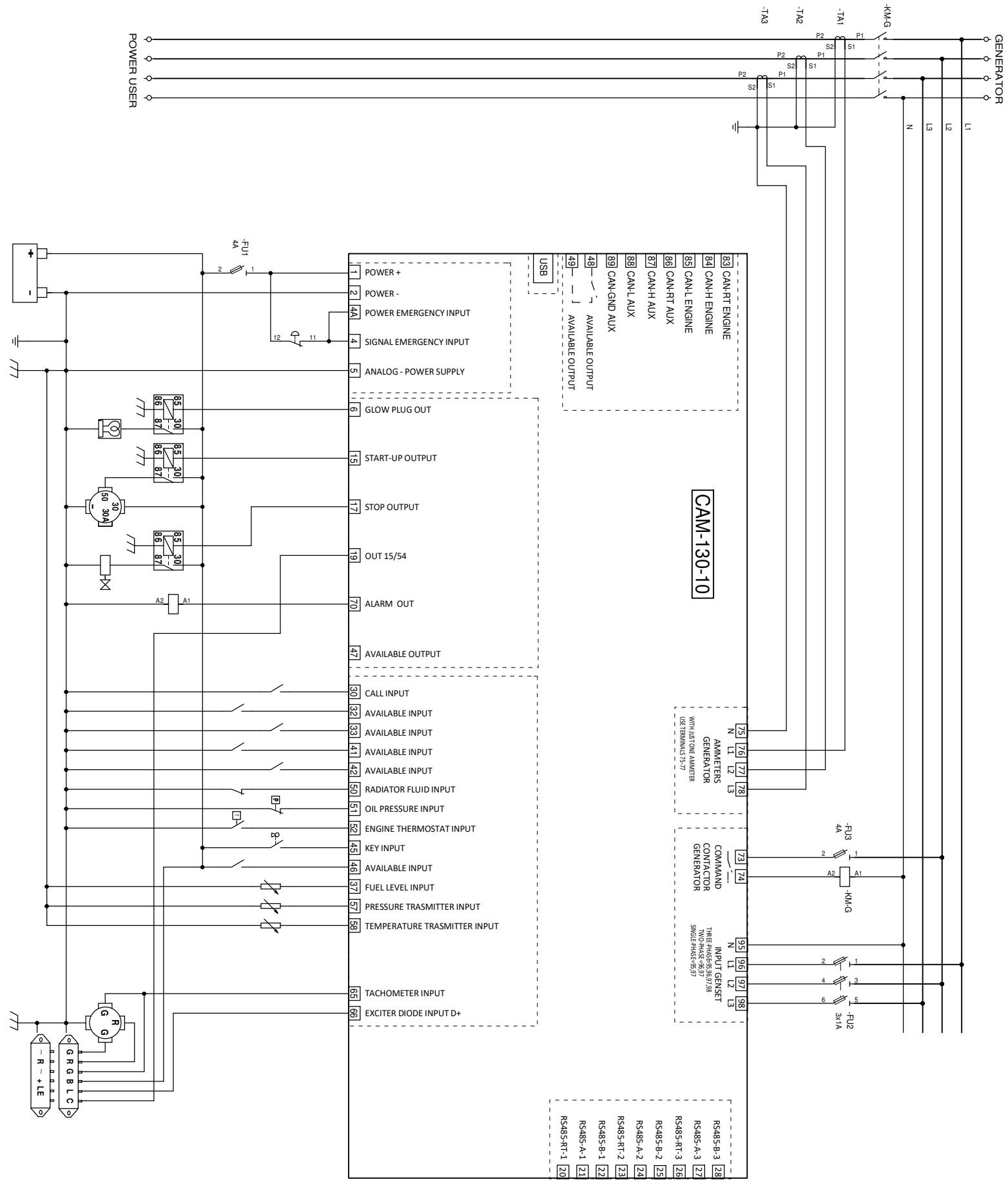

Detail of connection of the control unit to a permanent magnet battery charger alternator. For different controllers, request diagram.

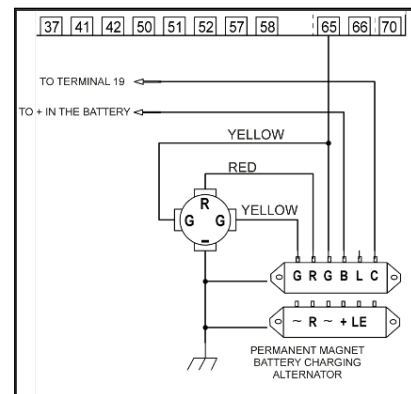

Detail of connection of the control unit to an electronic engine via CAN Bus. Use an insulated twisted-wire cable not longer than 40 metres. For additional details, request the diagrams for the specific engines.

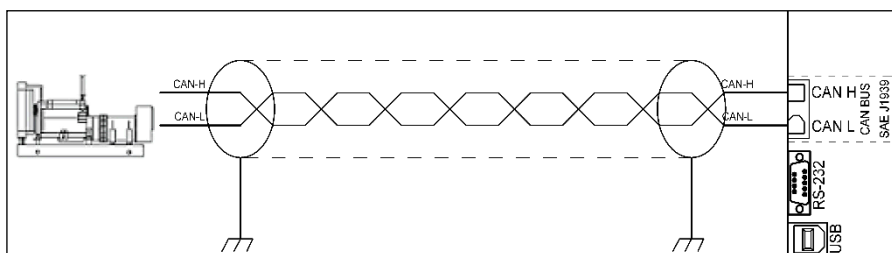

In the manual for the control unit (ECU/ECM), read if inserting the 120ohm 1/4W termination resistor, engine side, between the CAN-H and CAN-L wires is required.

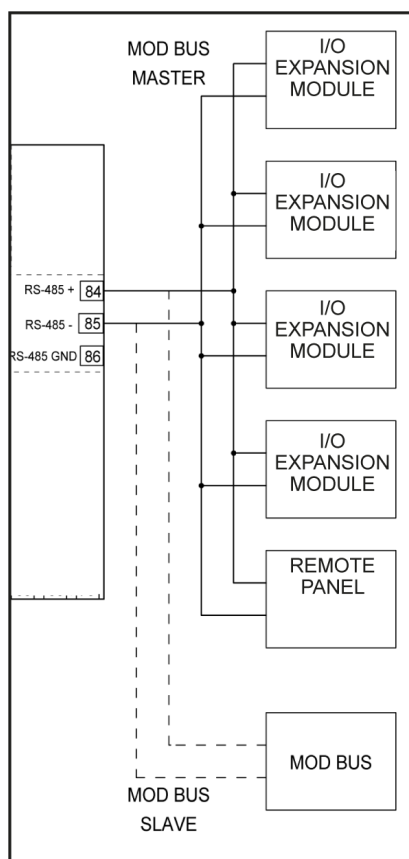

RS485 serial ports can act as a master to manage expansions or as a slave to be polled by external devices. E .g.. REMOTE PANEL.

Once the connections have been made and powered, the control unit is set to OFF. See programming to change this status.

USER PROGRAMMING

To access user programming, press the **FUNCTION** button and keep it pressed until "PROG" appears on the display



Release the button. After a few seconds:



Press the **UP** and **DOWN** arrows to scroll through the programming menus. Press **RIGHT** to enter the desired sub-menu. For example:



Press **UP** and **DOWN** to scroll through the programming items. For example:



Press **START** to confirm the selection. The following appears:



Wait for a few seconds:



The chosen parameter is now programmed in the control unit. The settings are stored in a non-volatile memory, and are therefore maintained even if the power is switched off. The value can be modified at any time by repeating the procedure as described above.

Press **STOP** to return to the previous menu and then proceed to set the other parameters.

PROGRAMMING A NUMERICAL PARAMETER

When programming a numerical parameter, such as a threshold or a time, press **UP** and **DOWN** to increase or decrease the value.

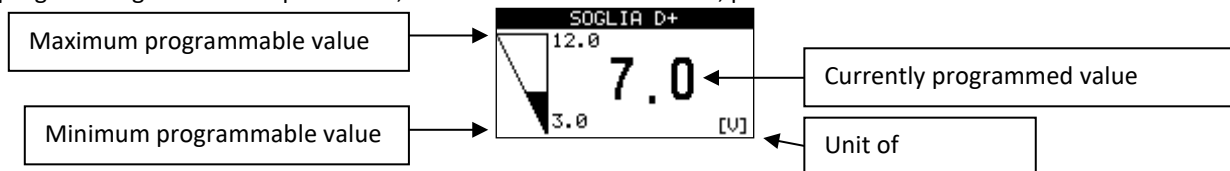

When the number is modified, it changes colour. Press **START** to set the value.

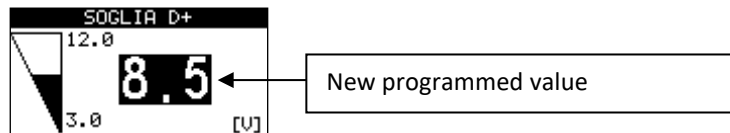

ENABLING/DISABLING A PARAMETER

When programming a binary parameter (enabled/disabled), for example, enabling the weekly automatic test, press **UP** and **DOWN** to enable or disable the parameter. For example:

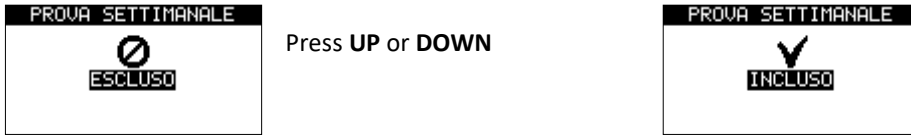

Press **START** to confirm the value.

PROGRAMMING A NUMBER

When programming a numerical code, for example, telephone numbers for the GSM modem, press **UP** and **DOWN** to edit the number indicated by the cursor. For example:

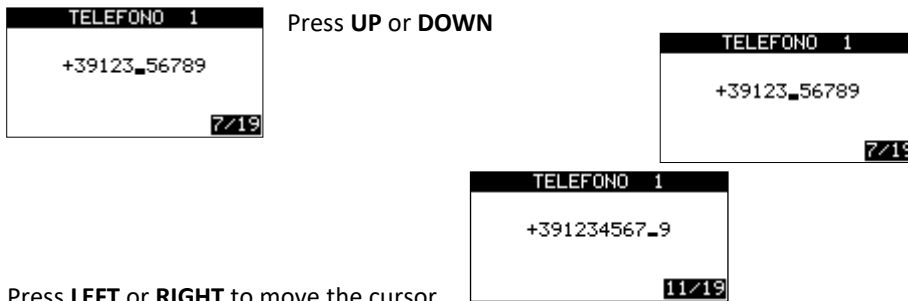

Confirm the programming by pressing **START**

User-programmable parameters are:

Parameter	Range	Factory settings	Notes	
LANGUAGE CHOICE	ITALIAN	ITALIAN	A CUSTOM language cannot be selected unless the messages have been programmed with the ZW-SMART software.	
	ENGLISH			
	FRENCH			
	GERMAN			
	SPANISH			
	PORTUGUESE			
	CUSTOM			
CLOCK/CALENDAR	Standard		Calendar clock adjustment.	
TELEPHONE NUMBERS	TELEPHONE 1	16 digits	Empty	Telephone numbers to which text messages will be sent with the GSM modem.
	TELEPHONE 2	16 cifre	Empty	
	TELEPHONE 3	16 cifre	Empty	
AUTOMATIC TEST	DISABLED		ESCLUSO	
	ENABLED			
DAILY START	START 1	00:00 ÷ 23:59	--:-- ÷ --:--	With --:-- ÷ --:-- starting is off.
	START 2	00:00 ÷ 23:59	--:-- ÷ --:--	
	START 3	00:00 ÷ 23:59	--:-- ÷ --:--	
	START 4	00:00 ÷ 23:59	--:-- ÷ --:--	
	START 5	00:00 ÷ 23:59	--:-- ÷ --:--	
	START 6	00:00 ÷ 23:59	--:-- ÷ --:--	
	START 7	00:00 ÷ 23:59	--:-- ÷ --:--	
	START 8	00:00 ÷ 23:59	--:-- ÷ --:--	
	START 9	00:00 ÷ 23:59	--:-- ÷ --:--	
	START 10	00:00 ÷ 23:59	--:-- ÷ --:--	
DAILY STOP	00:00 ÷ 23:59		--:-- ÷ --:--	With --:-- ÷ --:-- stopping is off..

REPLACING THE CONTROL UNIT

Before replacing the control unit, we advise you to transfer all the technical settings to a personal computer and save them in an archive file. This operation can be performed using the ZW-SMART software, which can be requested from Elcos or downloaded from the website www.elcos.it.

RESTORE FACTORY SETTINGS

Within 10 seconds of switching on the control unit, set the OFF mode and keep the START and STOP buttons pressed until the "FACTORY SETTINGS" message appears. All settings are restored to factory values. The control unit then performs a reset.

ACCESSING TECHNICAL PROGRAMMING

All programming must be done with the engine switched off. **The programming procedure is the same for all parameters.** As an example, the language programming is explained below, but the same procedure is used for all other programming.

To access the technical programming, press and hold down the **FUNCTION** button for 3 seconds until the "USER PROGRAM" menu appears on the display.



Press and hold **START** and **STOP** simultaneously for 5 seconds until the "PASSWORD" message appears on the display.



The control unit requires a password. The factory password 7 (DEVICE) is "2015" and all the others are "0000"; these can be changed by the user. Use the **ARROW** buttons to enter the code. Then press **START** to confirm the password and access the technical programming menus:



Press the two **UP** and **DOWN** buttons to scroll through the programming sub-menus. Press **RIGHT** to enter a sub-menu. For example:



Press the two **UP** and **DOWN** buttons to scroll through the programming items. For example:



Press **START** to confirm the selection. For example:

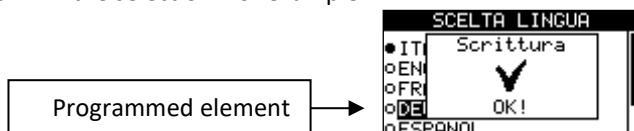

The chosen parameter is now programmed in the control unit. The settings are stored in a non-volatile memory, and are therefore maintained even if the power is switched off. The value can be modified at any time by repeating the procedure as described above.

Press **STOP** or **LEFT** to return to the previous menu and then proceed to set the other parameters. To completely exit the programming procedure, press the **FUNCTION** button.

TEXT STRING SETTINGS

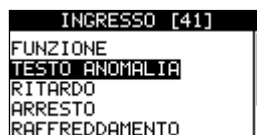

When programming text, such as fault or maintenance descriptions, press **RIGHT** to enter the page displaying the text.

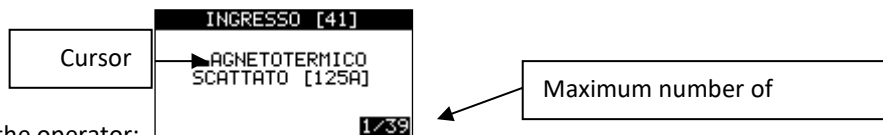

Example of message programmed by the operator:
 Press **UP** and **DOWN** to scroll through the alphanumeric characters. Press **LEFT** and **RIGHT** to move the cursor. Press **START** to set the saved text. The programmed texts are not translated by the control unit.
 Press **STOP** to return to the previous menu.



TECHNICAL PROGRAMMING

LANGUAGE CHOICE

Range	Factory settings
ITALIAN	ITALIAN
ENGLISH	
FRENCH	
GERMAN	
SPANISH	
PORTUGUESE	
CUSTOM	

All the messages displayed in the control unit can be programmed in any one of the resident languages using the ZW-SMART programming software. These messages will be activated by choosing the CUSTOM language.

CLOCK/CALENDAR

Parameter	Factory settings	Range	Notes
TYPE	ANALOGUE	ANALOGUE	Display type 
		DIGITAL	Display type 
DATE AND TIME		STANDARD	When switching off the control unit battery power the date and time are reset.
THERMOMETER	DISABLED	ENABLED	Displays the temperature inside the control unit.
		DISABLED	Does not display the control unit temperature.

CURRENT TRANSFORMERS (A.T.)

Parameter	Factory settings	Range	Notes
FUNCTION	ENABLED	ENABLED	Reading of currents included.
		DISABLED	Reading of currents excluded; power readings and related functions are also excluded (overloading, faults, power on demand).
RATIO	50/5	30/5, 40/5, 50/5, 60/5, 80/5, 100/5, 150/5, 200/5, 250/5, 300/5, 400/5, 500/5, 600/5, 800/5, 1000/5, 1200/5, 1600/5, 2000/5, 2500/5, 3000/5, 4000/5	For an accurate reading, use of the following cables is recommended: 1 metre – 1.5mm ² 2 metres – 2.5mm ² 3 metres – 4mm ²
AMMETER NUMBER	L1,L2,L3	L1,L2,L3	Connect the 3 A.T.s in the relative phases.
		L2	Connect only one ammeter to phase L2.

The control unit can read up to 110% of the selected ammeter transformer full scale current. Having set the transformer, the OVERLOAD PRE-ALARM and OVERLOAD thresholds are automatically adjusted respectively to 95% and 100% of the nominal value of the A.T.



VOLTAGE TRANSFORMERS (V.T.)

The generator 3-phase voltage applied to the control unit must not exceed 570 Vac. In applications with higher voltages, voltage transformers must be included in the system to reduce the voltages. For example, if the generator voltage is 690 Vac, insert three 800V3/100V3 transformers between the generator line and the control unit, then program the ratio 8:1 in the control unit. The control unit displays maximum voltages of 999Vac. Do not apply transformers with primary circuit voltages exceeding 800Vac. Having set the V.T., the generator voltage thresholds must then be set. Request the connection diagram, which can also be downloaded from the website www.elcos.it

Range	Factory settings	Notes
1:1 ÷ 8:1	1:1	Using voltage transformers (V.T.) on the generator voltage measuring inputs, we must set the voltage reduction ratio. With 1:1 settings, do not assemble the V.T.; rather, connect the generator phases directly to the control unit.

MOTOR RUNNING

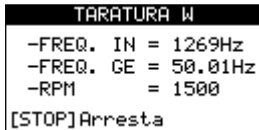
Normally no adjustment is required, if necessary set the voltage threshold from D+ on the charge alternator connected to terminal 66. If the RPM frequency readout is to be used (terminal W of the pre-excitation alternator, from the yellow wire on the permanent magnet alternator), tachometer calibration must be performed.

Parameter	Factory settings	Range	Notes
D+ THRESHOLD	7 V (for 12 V battery) 14 V (for 24 V battery)	(3 ÷ 12) to V [12 V] (6 ÷ 24) to V [24 V]	Engine running threshold with 66 connected to D+. Normally no adjustment is required.
RPM THRESHOLD	600 RPM	(300 ÷ 4000) RPM	Running engine threshold RPM.
W TACHOMETER CALIBRATION	<p>Procedure with tachometer calibration. Operation required with one of the following situations:</p> <ul style="list-style-type: none"> Terminal 65 connected to terminal W of the pre-excitation alternator Terminal 65 connected to the yellow wire on the permanent magnet alternator <p>Do not run this calibration when the control unit is connected to an electronic motor via the CAN Bus.</p> <div style="text-align: center;">  </div> <p>Press the RIGHT arrow to bring up the following window:</p> <div style="text-align: center;">  </div> <p>Press and hold START until the engine starts. When the engine starts, the display shows this information. Example:</p> <div style="text-align: center;">  </div> <p>Press START and wait</p> <p>Engine RPMs are associated with the frequency read by charge alternator "W".</p>		

GENERAL FUNCTIONS

This menu includes all the general settings of the control unit, including some parameters shared between the generator and the engine.

Parameter	Sub-parameter	Factory settings	Range	Notes
G.S. FREQUENCY		50 Hz	50 Hz	Automatically selects underfrequency and overfrequency parameters. When the control unit is connected to a SCANIA electronic motor with CAN Bus, by setting this parameter it is possible to modify the engine rpm to make it work at 50 or 60Hz.
			60 Hz	
PROTECTIONS IN MANUAL MODE		WITH STOP	WITH STOP	The engine is stopped in the event of a fault.
			WITHOUT STOP	The engine is not stopped even if faults have occurred. Exceptions to this are the emergency, the over frequency, the overspeed messages, as well as maintenance with stops and rental with stops messages. The faults are in any case displayed and the general alarm activates.
INDICATION OF FAULTS		WRITTEN INDICATION	WRITTEN INDICATION	Displays faults using alphanumeric characters.
			NUMERICAL CODE	Displays faults using a numerical code.
GENERAL ALARM	DURATION	350 sec	(10 ÷ 350) sec	The value 350 indicates continuous operation with no time limit.
	IMMINENT START	ENABLED	ENABLED	Warns that automatic start-up is imminent, sounding the intermittent alarm for 8 seconds. The start-up from call does not give any notification.
			DISABLED	Does not warn of the imminent start-up.

ENGINE

This menu includes all the engine settings.

Parameter (fault code)	Sub-parameter	Factory settings	Range	Notes			
ENGINE TYPE		DIESEL	DIESEL PETROL	Engine type selection.			
STOPPING SYSTEMS		ENERGIZED IN RUN MODE	ENERGIZED IN RUN MODE ENERGIZED IN STOP MODE	With "energized in stop mode", consult our technical department.			
BATTERY VOLTAGE		12 V	12 V 24 V	Battery voltage selection.			
BATTERY UNDERVOLTAGE (120)	FAULT	ENABLED	ENABLED DISABLED	The fault does not cause a stop and occurs when the battery voltage is equal to or lower than the set threshold for the whole duration of the cut-in delay. It is always enabled and is saved .			
	THRESHOLD	11 V [12V] 22 V [24V]	(8 ÷ 14) V [12V] (16 ÷ 28) V [24V]				
	DELAY	2 sec	(1 ÷ 5) sec				
BATTERY OVERVOLTAGE (121)	FAULT	ENABLED	ENABLED DISABLED	The fault cuts in when the battery voltage exceeds the set threshold for the whole duration of the cut-in delay. It is always enabled and is saved . If a stop occurs, it cools the system .			
	THRESHOLD	16 V [12V] 32 V [24V]	(12 ÷ 24) V [12 V] (24 ÷ 48) V [24 V]				
	DELAY	2 sec	(1 ÷ 5) sec				
	STOP	FAULT DOES NOT CAUSE A STOP	FAULT CAUSES A STOP FAULT DOES NOT CAUSE A STOP				
RPM		1500 / 1800 RPM	750 / 900 RPM	Tachometer adjustment to the generator frequency. Programming required when NOT using the "W" of the charge alternator.			
			1000 / 1200 RPM				
			1500 / 1800 RPM				
			3000 / 3600 RPM				
OVERSPEED (139)		1860 RPM	(900 ÷ 5100) RPM	The fault cuts in when the speed is higher than or equal to the set threshold for at least 2 seconds. Causes the engine to stop without cooling . The fault is saved . Here below, the values set automatically when the RPM is modified are shown.			
					RPM	Default setting	Hz
					750	930	62
					1000	1240	
					1500	1860	
					3000	3720	
					900	1110	74
					1200	1480	
					1800	2220	
					3600	4440	
TACHOMETER		ENABLED	ENABLED DISABLED	Instrument displayed. Used also to detect engine running from its RPM..			
GLOW PLUGS TIME	PREHEATING	0 sec	(0 ÷ 60) sec	Activated before start-up. 0 sec, pre-heating off. Too long a time can damage the glow plugs.			
	POST-HEATING	0 sec	(0 ÷ 60) sec	Enabled throughout engine start-up and for the set time. 0 sec, post-heating off..			
STARTING TIME		5 sec	(3 ÷ 25) sec	Activation of the starter motor.			
PAUSE TIME		5 sec	(1 ÷ 20) sec	Pause between start-up attempts.			
STOPPING TIME		20 sec	(0 ÷ 60) sec	Stopping system activation time with engine at a standstill.			
CALL TIME	INTERVENTION DELAY	1 sec	(1 ÷ 600) sec	With the call contact closed and delay expired, start-up sets off.			
	STOP DELAY	1 sec	(1 ÷ 600) sec	When the contact is open, power is cut to the generator contactor			
COOLING TIME		120 sec	(0 ÷ 600) sec	Engine operating time between release of generator contactor and activation of stopping system.			
ENGINE WARM-UP	TIME	0 sec	(0 ÷ 600) sec	With both settings to 0 the function is excluded. Used to heat the engine while idling until one of the two conditions is reached. Connect an electromagnet to the output associated to the "Engine heating". Function also possible with SCANIA engines with CAN Bus connection.			
	TEMPERATURE	0 °C	(0 ÷ 60) °C				
STARTUP ATTEMPTS (137)		4	(1 ÷ 15)	The start failure fault is saved .			
ENGINE THERMOMETER		DISABLED	ENABLED DISABLED	Includes or excludes the display of the temperature even when managed by the CAN Bus.			
ENGINE LOW TEMPERATURE (122)	FAULT	DISABLED	ENABLED DISABLED	The fault cuts in when the temperature falls below the set threshold for the whole duration of the cut-in delay. It is always enabled and is not saved . If programmed with			
	THRESHOLD	30 °C	(0 ÷ 60) °C				

	DELAY	30 min.	(1 ÷ 60) min.	stop, it prevents the engine from starting up. If a stop occurs, it cools the system
	STOP	FAULT DOES NOT CAUSE A STOP	FAULT CAUSES A STOP FAULT DOES NOT CAUSE A STOP	
OVERTEMPERATURE PRE-ALARM (123)	FAULT	ENABLED	ENABLED DISABLED	The fault cuts in when the temperature read by the transmitter exceeds the set threshold. It is always enabled and is saved . If a stop occurs, it cools the system .
	THRESHOLD	95 °C	(90 ÷ 140) °C	
	STOP	FAULT DOES NOT CAUSE A STOP	FAULT CAUSES A STOP FAULT DOES NOT CAUSE A STOP	
OVERTEMPERATURE (124)	FAULT	ENABLED	ENABLED DISABLED	The fault cuts in when the temperature read by the transmitter exceeds the set threshold. It is always enabled and is saved . If a stop occurs, it does not cool the system .
	THRESHOLD	100 °C	(90 ÷ 140) °C	
	STOP	FAULT CAUSES A STOP	FAULT CAUSES A STOP FAULT DOES NOT CAUSE A STOP	
OIL PRESSURE GAUGE		ENABLED	ENABLED DISABLED	Includes or excludes the display of the pressure even when managed by the CAN Bus.
LOW OIL PRESSURE PRE-ALARM (131)	FAULT	ENABLED	ENABLED DISABLED	The fault cuts in when the pressure measured by the transmitter is less than or equal to the set threshold for the whole duration of the cut-in delay. Does not stop the engine. Enabled for 10 seconds after engine running is detected. The fault is saved .
	THRESHOLD	0,5 Bar	(0 ÷ 6,0) Bar	
	DELAY	1 sec	(1 ÷ 5) sec	
FUEL RESERVE (129)	THRESHOLD	10 %	(0 ÷ 100) %	The fault cuts in when the fuel level is lower than or equal to the set threshold for the entire duration of the cut-in delay. It is always enabled. It does not stop and it is not saved .
	DELAY	1 sec	(1 ÷ 5) sec	
NO FUEL (130)	THRESHOLD	1 %	(0 ÷ 100) %	The fault cuts in when the fuel level is lower than or equal to the set threshold for the entire duration of the cut-in delay. It is always enabled and is saved . If a stop occurs, it cools the system .
	DELAY	3 sec	(1 ÷ 10) sec	
	STOP	FAULT CAUSES A STOP	FAULT CAUSES A STOP FAULT DOES NOT CAUSE A STOP	
CHARGING ALTERNATOR (136)	INPUT [66] D+	ENABLED	ENABLED DISABLED	Running engine detected by input 66 connected to charging alternator terminal D+. Exclusion to avoid: incomplete running engine detection.
	INPUT [65] W	ENABLED	ENABLED DISABLED	Running engine detected by input 65 connected to charging alternator terminal W. Exclusion to avoid: incomplete running engine detection.
	PRE-EXCITATION	ENABLED	ENABLED DISABLED	For pre-excitation alternators.
	STOP	FAULT DOES NOT CAUSE A STOP	FAULT CAUSES A STOP FAULT DOES NOT CAUSE A STOP	The fault cuts in when the alternator does not recharge the battery for 3 consecutive seconds. Enabled for 10 seconds after engine running is detected. It is saved . If a stop occurs, it does not cool the system .
START WITH FLAT BATTERY	FUNCTION	DISABLED	ENABLED DISABLED	The engine starts when the voltage read on the battery is lower than or equal to the minimum threshold for 60 seconds. The engine stops after the battery voltage exceeds the set threshold for the whole duration of the cut-in delay. Having stopped the engine, the control unit does not keep track of the start-up due to a flat battery.
	MINIMUM THRESHOLD	12,4 V	(12,2 ÷ 12,7) V [12V] (24,4 ÷ 25,4) V [24V]	
	MAXIMUM THRESHOLD	13,6 V	(13,5 ÷ 14,5) V [12V] (27,0 ÷ 29,0) V [24V]	
	DELAY	1200 sec	(900 ÷ 7200) sec	
STOPPING FAILURE (133)	FUNCTION	ENABLED	ENABLED DISABLED	The fault cuts in when the control unit detects the engine running after activating the stopping system and after the delay time has elapsed. It is saved .
	DELAY	120 sec	(0 ÷ 120) sec	
RADIATOR COOLANT LEVEL PROBE		NORMAL	NORMAL INVERTED	If there is no liquid it switches off the ground signal. If there is no liquid it switches on the ground signal.
OIL PRESSURE SWITCH CHECK (141)	WITH ENGINE RUNNING		WITH ENGINE RUNNING	Checks only the opening of the contact with the engine running.
			BEFORE START-UP	Also checks closing of contact with engine switched off.

THERMOSTAT OVERTEMPERATURE (125)	Thermostat overtemperature has no programming. It is activated after detecting that the engine is running and stops without cooling the system . The fault is saved .
----------------------------------	---

LOW OIL PRESSURE (132)	The low oil pressure from pressure switch has no programmable threshold. It is activated 10 seconds after detecting that the engine is running and stops without cooling the system . The fault is saved .
------------------------	--

LOW RADIATOR LEVEL (135)	The fault cuts in when the coolant falls below the electrode for 5 consecutive seconds. Stops the engine with cooling . The fault is saved .
--------------------------	---

CAN BUS SAE J1939

Programming required when the CAM-130-10 is connected via CAN Bus to a control unit for the electronic management of the injection system (ECU / ECM).

Parameter	Sub-parameter	Factory settings	Range	Notes
TIPO MOTORE		MECHANICAL ENGINE	MOTORE MECCANICO	Choice of engine type equipped with control unit for electronic control of the injection system (ECM / ECU).
			JOHN DEERE	
			PERKINS 110X/220X	
			SCANIA	
			VOLVO TAD124X/94X	
			DEUTZ EMR2/EMR3	
			FPT NEF/CURSOR	
			VM R756 IE3	
			CUMMINS CM850	
			MTU	
			GENERIC	
START TRIGGERED FROM CAN BUS		ENABLED	ENABLED DISABLED	Used to start the engine via the CAN Bus.
INJECTION OFF TIME		30 sec	(0 ÷ 60) sec	Time for which the control unit keeps the injection signal disabled before entering standby (is added to STANDBY INPUT TIME in the DEVICE menu)
SWITCHING OFF INSTRUMENTS	FUEL USED	ENABLED	ENABLED DISABLED	Instruments displayed on the control unit..
	INSTANT CONSUMPTION	ENABLED	ENABLED DISABLED	
	FUEL TEMPERATURE	ENABLED	ENABLED DISABLED	
	TURBO TEMPERATURE	ENABLED	ENABLED DISABLED	
	OIL TEMPERATURE	ENABLED	ENABLED DISABLED	
	INTERCOOLER TEMPERATURE	ENABLED	ENABLED DISABLED	
	INTAKE TEMPERATURE	ENABLED	ENABLED DISABLED	
	FUEL PRESSURE	ENABLED	ENABLED DISABLED	
	COOLANT LEVEL	ENABLED	ENABLED DISABLED	
	COOLANT PRESSURE	ENABLED	ENABLED DISABLED	
	ENGINE TORQUE	DISABLED	ENABLED DISABLED	
	ENGINE LOAD	ENABLED	ENABLED DISABLED	
	FUEL LEVEL	DISABLED	ENABLED DISABLED	
	OIL LEVEL	ENABLED	ENABLED DISABLED	

Here below, a list of engine control units (ECU / ECM) that can be connected to the CAM-130-10.

Engine manufacturer	Engine / Control unit	CAM-130-10 Functions
JOHN DEERE	Engine series 4045, 6068	Reads and displays the instruments transmitted on the CAN Bus line. Reads and views all the SPN / FMI errors. Electromechanical start-up and stop.
PERKINS	Engine series 1100, 2200, 2800	Reads and displays the instruments transmitted on the CAN Bus line. Reads and views all the SPN / FMI errors. Electromechanical start-up and stop. Possibility to manage the glow plugs via a CAN Bus control.
SCANIA	Control unit EMS/S6	Reads and displays the instruments transmitted on the CAN Bus line. Reads and views all the SPN / FMI errors. Possibility to manage and stop via a CAN Bus control. Possibility to modify 50Hz or 60Hz via a CAN Bus control. Possibility to heat the engine via a CAN Bus control.
VOLVO	Control unit EDC3, EMS, EMS2	Reads and displays the instruments transmitted on the CAN Bus line. Reads and views all the SPN / FMI errors. Electromechanical start-up and stop.

DEUTZ	Control unit EMR2, EMR3, EDC16	Reads and displays the instruments transmitted on the CAN Bus line. Reads and views all the SPN / FMI errors. Electromechanical start-up and stop.
FPT	Control unit EDC7, EDC7UC31	Reads and displays the instruments transmitted on the CAN Bus line. Reads and views all the SPN / FMI errors. Electromechanical start-up and stop.
VM	Control unit EDC16	Reads and displays the instruments transmitted on the CAN Bus line. Reads and views all the SPN / FMI errors. Electromechanical start-up and stop.
CUMMINS	Control unit CM850	Reads and displays the instruments transmitted on the CAN Bus line. Reads and views all the SPN / FMI errors. Electromechanical start-up and stop.
MTU	Engine series 1600	Reads and displays the instruments transmitted on the CAN Bus line. Reads and views all the SPN / FMI errors. Electromechanical start-up and stop.

GENERATOR

Parameter (fault code)	Sub-parameter	Factory settings	Range	Notes
CONNECTION TYPE		THREE PHASE N-L1-L2-L3	THREE PHASE N-L1-L2-L3	Connect terminals 95, 96, 97, 98.
			TWO-PHASE L1-L2	Connect terminals 96, 97.
			SINGLE PHASE N-L2	Connect terminals 95, 97.
UNDERVOLTAGE (220)	FAULT	ENABLED	ENABLED DISABLED	The generator voltage is lower than or equal to the set threshold for the whole duration of the cut-in delay. Opens the generator contactor. The protection is enabled 10 seconds after the threshold is exceeded. If a stop occurs, it cools the system . The fault is saved .
	THRESHOLD	335 V [Three-phase and two-phase] 193 V [Single-phase]	(50 ÷ 999) V	
	DELAY	3 sec	(0 ÷ 10) sec	
	STOP	FAULT CAUSES A STOP	FAULT CAUSES A STOP FAULT DOES NOT CAUSE A STOP	
VOLTAGE PRESENT	THRESHOLD	355 V [Three-phase and two-phase] 205 V [Single-phase]	(50 ÷ 999) V	The voltage remains stable above the threshold for the whole duration of the delay. It can close the generator contactor.
	DELAY	7 sec	(0 ÷ 600) sec	
OVERVOLTAGE (222)	FAULT	ENABLED	ENABLED DISABLED	The generator voltage remains greater than or equal to the set threshold for the whole duration of the cut-in delay. The protection is enabled after the engine running has been detected. If a stop occurs, it does not cool the system . The fault is saved .
	THRESHOLD	440 V [Three-phase and two-phase] 254 V [Single-phase]	(50 ÷ 999) V	
	DELAY	3 sec	(0 ÷ 10) sec	
	STOP	FAULT CAUSES A STOP	FAULT CAUSES A STOP FAULT DOES NOT CAUSE A STOP	
UNDERFREQUENCY (223)	FAULT	ENABLED	ENABLED DISABLED	The generator frequency is lower than or equal to the set threshold for the whole duration of the cut-in delay. The protection is enabled 10 seconds after the threshold is exceeded. If a stop occurs, it cools the system . The fault is saved .
	THRESHOLD	45 Hz	(1 ÷ 60) Hz	
	DELAY	5 sec	(0 ÷ 10) sec	
	STOP	FAULT CAUSES A STOP	FAULT CAUSES A STOP FAULT DOES NOT CAUSE A STOP	
OVERFREQUENCY (224)	FAULT	ENABLED	ENABLED DISABLED	The generator frequency remains greater than or equal to the set threshold for the whole duration of the cut-in delay. Opens the generator contactor. The protection is always active. If a stop occurs, it does not cool the system . The fault is saved .
	THRESHOLD	60 Hz [50 Hz] 72 Hz [60 Hz]	(45 ÷ 85) Hz	
	DELAY	2 sec	(0 ÷ 10) sec	
	STOP	FAULT CAUSES A STOP	FAULT CAUSES A STOP FAULT DOES NOT CAUSE A STOP	
OVERLOAD PRE-ALARM (225)	FAULT	ENABLED	ENABLED DISABLED	The generator current remains greater than or equal to the set threshold for the whole duration of the cut-in delay. The protection is always active. Does not stop the engine and is not saved .
	THRESHOLD	47,5 A	0 ÷ full scale of the A.T.	
	DELAY	10 sec	(0 ÷ 60) sec	
OVERLOAD (226)	FAULT	ENABLED	ENABLED DISABLED	The generator current remains greater than or equal to the set threshold for the whole duration of the cut-in delay. The protection is always active. Opens the generator contactor. If a stop occurs, it cools the system . The fault is saved .
	THRESHOLD	50 A	0 ÷ full scale of the A.T.	
	DELAY	10 sec	(0 ÷ 60) sec	
	STOP		FAULT CAUSES A STOP	

		FAULT CAUSES A STOP	FAULT DOES NOT CAUSE A STOP	
GENERATOR NOT DELIVERING (227)	FAULT	ENABLED	ENABLED	The generator does not generate voltage for the whole duration of the cut-in delay. The protection is always active. If a stop occurs, it does not cool the system . The fault is saved .
	DELAY	60 sec	(0 ÷ 180) sec	
	STOP	FAULT DOES NOT CAUSE A STOP	FAULT CAUSES A STOP FAULT DOES NOT CAUSE A STOP	
ASYMMETRY (231)	FAULT	ENABLED	ENABLED	The percentage difference between generator voltages remains above the set threshold for the whole duration of the cut-in delay. The protection is always active. Opens the generator contactor. This imbalance represents the increase or decrease in voltage between the phases. If a stop occurs, it cools the system . The fault is saved .
	THRESHOLD	15 %	(5 ÷ 20) %	
	DELAY	15 sec	(0 ÷ 600) sec	
	STOP	FAULT DOES NOT CAUSE A STOP	FAULT CAUSES A STOP FAULT DOES NOT CAUSE A STOP	
INCORRECT PHASE SEQUENCE (230)	FAULT	ENABLED	ENABLED	The phase connections are incorrect. It does not close the generator contactor. If a stop occurs, it does not cool the system . The fault is not saved .
	STOP	FAULT CAUSES A STOP	FAULT CAUSES A STOP FAULT DOES NOT CAUSE A STOP	
OVERPOWER (221)	FAULT	DISABLED	ENABLED	The power delivered by the generator remains greater than or equal to the set threshold for the whole duration of the cut-in delay. The protection is always active. Opens the generator contactor. If a stop occurs, it cools the system . The fault is saved .
	THRESHOLD	3000 kW	(0 ÷ 3000) kW	
	DELAY	10 sec	(0 ÷ 60) sec	
	STOP	FAULT DOES NOT CAUSE A STOP	FAULT CAUSES A STOP FAULT DOES NOT CAUSE A STOP	
SWITCHING OFF INSTRUMENTS	KWATTMETER	ENABLED	ENABLED	Instruments displayed on the control unit.
			DISABLED	
	KVARMETER	DISABLED	ENABLED	
			DISABLED	
	KVOLTAMMETER	DISABLED	ENABLED	
			DISABLED	
POWER FACTOR INDICATOR	DISABLED	ENABLED		
		DISABLED		
KILOWATT-HOUR	DISABLED	ENABLED		
		DISABLED		

AUTOMATIC TEST

The automatic test can be run weekly or timed. The weekly mode runs the test on the day and at the time set. The timed mode runs the test the first time during programming and afterwards at cycles which can be scheduled. The time count resumes again when the control unit is reset. You can choose whether to run a commutation or not during the test (default setting: no commutation).

Parameter	Factory settings	Range	Notes
FUNCTION	DISABLED	ENABLED DISABLED	Whether or not to run the test
DURATION	3 min	(1 ÷ 60) min	After the end of the test duration, the engine will stop.
MODE	TIMED	WEEKLY	The test is run on the set day and at the set time. (Available from FW1.13)
		TIMED	The test is run for the first time after completing any weekly test menu setting and after returning to automatic.
TEST FREQUENCY	Displayed only if MODE = TIMED 7 days	Test frequency.	Test frequency.
DAY	Displayed only if MODE = WEEKLY SUNDAY	Day test is run	Day test is run
HOUR		00:00	Run time
SWITCHING	DISABLED	ENABLED DISABLED	It is possible to select whether to switch the power user to the generator during the test.

CHOICE OF TRANSMITTERS

Parameter (fault code)	Sub-parameter	Factory settings	Range	Notes
TEMPERATURE TRANSMITTER (447)	FUNCTION	DISABLED	ENABLED	Possibility to exclude or include the engine thermometer.
			DISABLED	
	TYPE	TTAO/402	TTAO/402	Tables already entered in the control unit.
			VDO/120	
			VDO/150	
			BERU	
			VEGLIA	
			JCB/1707	
			LOMBARDINI	
			F16173	
	CUSTOM	Select this parameter when programming the table with customised settings.		
	UNIT OF MEASUREMENT	°C	°C	Temperature expressed in Degrees Celsius.
			°F	Temperature expressed in Degrees Fahrenheit.
CUSTOM TABLE	----	25°C = 0 - 3000 ohm	Programmable table. Associates the temperature degrees to the transmitter resistance. Warning: at least 2 values must be programmed; to obtain an accurate reading, it is advisable to program at least 4 monotonic values. Programming only one value will generate a fault (Temperature Table Error).	
	----	50°C = 0 - 3000 ohm		
	----	70°C = 0 - 3000 ohm		
	----	80°C = 0 - 3000 ohm		
	----	85°C = 0 - 3000 ohm		
	----	90°C = 0 - 3000 ohm		
	----	95°C = 0 - 3000 ohm		
	----	100°C = 0 - 3000 ohm		
	----	120°C = 0 - 3000 ohm		
----	130°C = 0 - 3000 ohm			
PRESSURE TRANSMITTER (446)	FUNCTION	DISABLED	ENABLED	Possibility to exclude or include the oil pressure gauge.
			DISABLED	
	TYPE	TPO/403	TPO/403	Tables already entered in the control unit.
			VDO	
			VDO 29/10	
			LOMBARDINI	
			[10-180] ohm	
			[240-33.5] ohm	
	CUSTOM	Select this parameter when programming the table with customised settings.		
	UNIT OF MEASUREMENT	BAR	BAR	Pressure expressed in BAR.
			kPa	Pressure expressed in kPa
	CUSTOM TABLE	----	0 BAR = 0 - 360 ohm	Programmable table. Associates the pressure to the transmitter resistance. Warning: at least 2 values must be programmed; to obtain an accurate reading, it is advisable to program at least 4 monotonic values. Programming only one value will generate a fault (Pressure Table Error).
		----	1 BAR = 0 - 360 ohm	
----		2 BAR = 0 - 360 ohm		
----		3 BAR = 0 - 360 ohm		
----		4 BAR = 0 - 360 ohm		
----		5 BAR = 0 - 360 ohm		
----		6 BAR = 0 - 360 ohm		
----		7 BAR = 0 - 360 ohm		
----		8 BAR = 0 - 360 ohm		
----	9 BAR = 0 - 360 ohm			
FUEL FLOAT (443)	FUNCTION	ENABLED	ENABLED	Possibility to exclude or include the fuel level.
			DISABLED	
	TYPE	VEGLIA	VEGLIA	Tables already entered in the control unit.
			VDO	
			DATCON	
			[10-180] ohm	
			[240-33.5] ohm	
			WITH CONTACT (W)	
	CUSTOM	Select this parameter when programming the table with customised settings.		
	CUSTOM TABLE	----	0% = 0 - 360 ohm	Programmable table. Associates the fuel tank level with the float resistance. Warning: at least 2 values must be programmed; to obtain an accurate reading, it is advisable to program at least 4 monotonic values. If only one value is programmed, a fault is generated (Incorrect Fuel Float Table).
		----	10% = 0 - 360 ohm	
		----	20% = 0 - 360 ohm	
		----	30% = 0 - 360 ohm	
----		40% = 0 - 360 ohm		
----		50% = 0 - 360 ohm		
----		60% = 0 - 360 ohm		
----		70% = 0 - 360 ohm		
----		80% = 0 - 360 ohm		
----	90% = 0 - 360 ohm			

		----	100% = 0 - 360 ohm	
--	--	------	--------------------	--

The control unit has already recorded some values of temperature, pressure and fuel float. The values of the tables already entered in the control unit are given below.

Temperature transmitter tables already entered in the control unit										
Type	25°C	50°C	70°C	80°C	85°C	90°C	95°C	100°C	120°C	130°C
TTAO/402	896 Ω	365 Ω	196 Ω	145 Ω	127 Ω	110 Ω	97 Ω	85 Ω	53 Ω	30 Ω
VDO/120	544 Ω	197 Ω	97 Ω	70 Ω	60 Ω	51 Ω	44 Ω	38 Ω	22 Ω	17 Ω
VDO/150	909 Ω	324 Ω	157 Ω	113 Ω	97 Ω	83 Ω	72 Ω	62 Ω	37 Ω	29 Ω
BERU	4036 Ω	1259 Ω	560 Ω	387 Ω	324 Ω	273 Ω	231 Ω	196 Ω	106 Ω	80 Ω
VEGLIA		708 Ω	399 Ω	245 Ω	210 Ω	175 Ω	153 Ω	130 Ω	75 Ω	59 Ω
JCB/1707	503 Ω	200 Ω	105 Ω	78 Ω	67 Ω	59 Ω	51 Ω	45 Ω		9
LOMBARDINI	927 Ω	322 Ω	155 Ω	112 Ω	96 Ω	83 Ω	71 Ω	62 Ω	36 Ω	29 Ω
F16173	2130 Ω	834 Ω	435 Ω	323 Ω	280 Ω	243 Ω	213 Ω	186 Ω	114 Ω	91 Ω

Pressure transmitter tables already entered in the control unit										
Type	0BAR	1BAR	2BAR	3BAR	4BAR	5BAR	6BAR	7BAR	8BAR	9BAR
TPO/403	270 Ω	251 Ω	203 Ω	157 Ω	114 Ω	79 Ω	47 Ω	32 Ω	23 Ω	1 Ω
VDO	10 Ω		50 Ω		85 Ω		119 Ω		152 Ω	
VDO 29/10	9 Ω	38 Ω	57 Ω	77 Ω	99 Ω	114 Ω	134 Ω	149 Ω	164 Ω	180 Ω
LOMBARDINI	10 Ω	31 Ω	52 Ω	71 Ω	90 Ω	107 Ω	124 Ω	140 Ω	156 Ω	170 Ω
[10-180] Ω	10 Ω	27 Ω	44 Ω	61 Ω	78 Ω	95 Ω	112 Ω	129 Ω	146 Ω	163 Ω
[240-33,5] Ω	240 Ω	219 Ω	199 Ω	178 Ω	157 Ω	137 Ω	116 Ω	95 Ω	75 Ω	54 Ω

Fuel float tables already entered in the control unit		
Type	0%	100%
VEGLIA	300 Ω	0 Ω
VDO	10 Ω	181 Ω
DATCON	240 Ω	37 Ω
[10-180] Ω	10 Ω	180 Ω
[240-33,5] Ω	240 Ω	34 Ω

MAINTENANCE AND RENTAL

It is possible to program the number of genset rental hours; after this time has elapsed, the control unit can immediately block genset operation or can block it at the next start-up. It is also possible to program the periodical maintenance text displayed when these must be performed.

Parameter (fault code)	Sub-parameter	Factory settings	Range	Notes
MAINTENANCE 1 (111)	THRESHOLD	0 h	(0 ÷ 59999) h	Number of hours after which a maintenance failure is triggered.
	STOP	FAULT DOES NOT CAUSE A STOP	FAULT CAUSES A STOP	Enables the alarm and prevents subsequent start-ups.
			FAULT DOES NOT CAUSE A STOP	Enables the general alarm for 10 seconds.
MESSAGE	"MAINTENANCE 1"	"0 ÷ Z"	Text displayed when maintenance fault is triggered.	
MAINTENANCE 2 (112)	THRESHOLD	0 h	(0 ÷ 59999) h	Number of hours after which a maintenance failure is triggered.
	STOP	FAULT DOES NOT CAUSE A STOP	FAULT CAUSES A STOP	Enables the alarm and prevents subsequent start-ups.
			FAULT DOES NOT CAUSE A STOP	Enables the general alarm for 10 seconds.
MESSAGE	"MAINTENANCE 2"	"0 ÷ Z"	Text displayed when maintenance fault is triggered.	
MAINTENANCE 3 (113)	THRESHOLD	0 h	(0 ÷ 59999) h	Number of hours after which a maintenance failure is triggered.
	STOP	FAULT DOES NOT CAUSE A STOP	FAULT CAUSES A STOP	Enables the alarm and prevents subsequent start-ups.

			FAULT DOES NOT CAUSE A STOP	Enables the general alarm for 10 seconds.
	MESSAGE	"MAINTENANCE 3"	"0 - Z"	Text displayed when maintenance fault is triggered.
CYCLICAL MAINTENANCE (114)	THRESHOLD	0 h	(0 ÷ 59999) h	Hour intervals for programmed maintenance.
	STOP	WITHOUT STOP	WITHOUT STOP	Enables the alarm for 10 seconds.
			START-UP BLOCK	Prevents subsequent start-ups.
			IMMEDIATE STOP	Immediately stops the system and prevents subsequent start-ups.
RENTAL (115)	THRESHOLD	0 h	(0 ÷ 59999) h	Rental hours. Decrease with the engine running.
	STOP	WITHOUT STOP	WITHOUT STOP	Enables the alarm for 10 seconds.
			START-UP BLOCK	Prevents subsequent start-ups.
			IMMEDIATE STOP	Immediately stops the system and prevents subsequent start-ups.
RESET	PREVENTIVE MAINTENANCE 1		Resets maintenance 1 parameter.	The yellow warning light goes out when all the expired maintenance faults are deleted.
	PREVENTIVE MAINTENANCE 2		Resets maintenance 2 parameter.	
	PREVENTIVE MAINTENANCE 3		Resets maintenance 3 parameter.	
	CYCLICAL MAINTENANCE		The count of hours in the maintenance cycle restarts from the time set as the threshold.	
	RENTAL		Resets the rental parameter.	

RESETTING

In this menu it is possible to reset or modify some parameters such as the total operating hours.

Parameter	Range	Notes
HOURL-METER	0 - 59999 h	Used to modify the operating hour intervals. The hour intervals for periodical maintenance must be reset.
KILOWATT-HOUR		Resets the generator kilowatt-hours.
START-UPS		Resets the engine start-up counter.
START-UP FAILURES		Resets the failed start-ups counter.
FUEL USED		Resets the litres of consumed fuel; valid only with a CAN Bus connection.
BLOCK VIA GSM		Lets you delete the GSM block command. Equivalent to the text message command for resetting the block.

SWITCHING OFF FUNCTIONS

Parameter	Factory settings	Range	Notes
AUTOMATIC MODE	ENABLED	ENABLED	It is possible to bypass automatic mode.
		DISABLED	
MANUAL MODE	ENABLED	ENABLED	It is possible to bypass manual mode.
		DISABLED	
OFF MODE	ENABLED	ENABLED	It is possible to bypass off mode.
		DISABLED	
TEXT MESSAGE ON EVERY START-UP AND STOP	DISABLED	ENABLED DISABLED	If included, it sends a text message on every generator set start-up and stop.
TEXT MESSAGE FOR SWITCHING TO AUTOMATIC MODE	DISABLED	ENABLED DISABLED	If included, it is possible to force the control unit to automatic mode using the "AUT MODE" text message command.
TEXT MESSAGE FOR SWITCHING TO OFF MODE	DISABLED	ENABLED DISABLED	If included, it is possible to force the control unit to off mode using the "OFF MODE" text message command.
TEXT MESSAGE FOR CYCLICAL MAINTEN. RESET	DISABLED	ENABLED DISABLED	If included, a text message command can reset the expired and due maintenance. Request the text message code from Elcos.
TEXT MESSAGE FAULT RESET	DISABLED	ENABLED	If enabled, it is possible to use the "RESET" text message command to reset any errors. Equal to reset using the front buttons.
		DISABLED	
GSM ANTITAMPER FUNCTION	DISABLED	ENABLED	If included, it can be used to block the generator set with a text message command and it is impossible to access the telephone number programming. Request the text message code from Elcos.
		DISABLED	

STAND BY

Parameter	Factory settings	Range	Notes
FUNCTION	ENABLED	ENABLED	Enables or disables the unit's power saving mode or Stand-By.
		DISABLED	

STAND-BY INPUT TIME	30 s	(1 ÷ 1800) s	This is how long the unit takes to time out to power saving Stand-By mode and turn off.
STANDBY INPUT FAULT	ENABLED	ENABLED	If enabled, the control unit goes into power saving mode even if a fault is present.
		DISABLED	

FAULT LOG

Parameter	Notes
DISPLAY	<p>Used to display the log of the last 50 faults that stopped the engine.</p> <div style="border: 1px solid black; padding: 5px; width: fit-content; margin: 10px auto;"> <p style="text-align: center; margin: 0;">STORICO ANOMALIE</p> <p style="margin: 0;">0012Min 6016</p> <p style="margin: 0; text-align: center;">Bassa pressione olio motore</p> <p style="margin: 0;">10:38 21Apr2015</p> </div> <p>Press the RIGHT arrow to bring up the following window:</p> <ul style="list-style-type: none"> the fault recorded the total working hours the time and date saved when the fault was triggered. If the clock/calendar is not set, "Time and Date missing" will appear in place of the time and date. <p>Press UP and DOWN to scroll through the entire list of recorded faults.</p> <p>The data displayed includes:</p>
RESET LOG	Complete log reset.

COMMUNICATION PORTS

Menu used to access the serial port parameters.

Parameter	Sub-parameter	Factory settings	Range	Notes
RS485 A	ADDRESS	1	1 ÷ 32	Address of the control unit with MOD Bus RTU Slave protocol.
	BAUD RATE	9600	1200 ÷ 115200	Communication speed.
	PARAMETERS	E,8,1	E,8,1 N,8,1 O,8,1	Communication parameters.
RS485 B	ADDRESS	2	1 ÷ 32	Address of the control unit with MOD Bus RTU Slave protocol.
	BAUD RATE	9600	1200 ÷ 115200	Communication speed.
	PARAMETERS	E,8,1	E,8,1 N,8,1 O,8,1	Communication parameters.
RS485 C	ADDRESS	3	1 ÷ 32	Address of the control unit with MOD Bus RTU Slave protocol.
	BAUD RATE	9600	1200 ÷ 115200	Communication speed.
	PARAMETERS	E,8,1	E,8,1 N,8,1 O,8,1	Communication parameters.
USB	VCP ADDRESS	1	1 ÷ 32	Address of the virtual com used by the USB.

EXPANSIONS

It is possible to connect a remote panel to the control unit using the RS485 serial port to display the instruments and up to 4 input/output expansion modules (MDE-088) to include more fault types and remote signals.

Parameter (fault code)	Sub-parameter	Factory settings	Range	Notes
REMOTE PANEL		----	----	REMOTE PANEL not connected to the control unit.
		----	RS485 A RS485 B RS485 C	REMOTE PANEL connected to the RS485 port. With this setting, the RS485 port is set to communicate with BAUDRATE: 115200, PARAMETERS: N,8,1. The port's configuration may be modified in the menu COMMUNICATION PORTS. <u>STAND-BY</u> is disabled
MODULE IN/OUT (506 ÷ 509)	MODULE CONNECTION	RS485 A	RS485 A RS485 B RS485 C	IN/OUT MODULES connected to the RS485 port, if present.
	MODULE ADDRESS	0	0 ÷ 4	Number of expansions connected to the RS485 serial port in Master mode. 0 indicates no module connected.
	MODULE XX (Xx=1) ADDRESS	1	1 ÷ 32	MODBus address of expansion module 1.
	MODULE XX (Xx=2) ADDRESS	2	1 ÷ 32	MODBus address of expansion module 2.

	MODULE XX (Xx=3) ADDRESS	3	1 ÷ 32	MODBus address of expansion module 3.
	MODULE XX (Xx=4) ADDRESS	4	1 ÷ 32	MODBus address of expansion module 4.
GSM MODEM	GSM CONNECTION	----	----	Modem not connected to the control unit.
			RS485 A RS485 B RS485 C	Modem connected to the RS485 port. With this setting, the parameter RS485 is not visible in the COMMUNICATION PORTS menu as the settings are pre-defined (9600 N, 8, 1).
			MAIN NO. ONLY	Only SMS commands from the main telephone number (the first in the phone book) are accepted.
	COMMANDS VIA SMS	NUMBERS IN PHONE BOOK ONLY	NUMBERS IN PHONE BOOK ONLY	SMS commands are accepted from all phone numbers in the phone book.
			QUALSIASI	SMS commands are accepted from all phone numbers, even if they are not in the phone book.
	FAULT SMS	3	0 ÷ 10	Number of times a fault SMS will be sent in the event that no "OK" reply is received. With 0, no fault SMS messages are sent.
MODEM MODEL	AMD-RB900/PRO	MOXA G2111 AMD-RB900/PRO	Select the type of modem installed.	

PROGRAMMABLE INPUTS

Inputs 32, 33, 41 and 42, are fully programmable. The possible settings are given below:

<i>Parameter (fault code)</i>	<i>Sub-parameter</i>	<i>Factory settings</i>	<i>Range</i>	<i>Notes</i>
INPUT [32] (426)	FUNCTION	REMOTE START-UP	<i>See programmable input functions table.</i>	It is possible to associate the input to a function among those listed in the programmable input functions table.
	DELAY	1 sec	0 - 600 sec	Cut-in delay.
	FAULT TEXT	<i>Empty</i>	"0 - Z"	Text displayed when a fault is associated to the input. The text is not translated automatically.
	STOP	FAULT DOES NOT CAUSE A STOP	FAULT CAUSES A STOP FAULT DOES NOT CAUSE A STOP	Settings valid only when a fault is associated to the input.
	COOLING	WITHOUT COOLING	WITH COOLING WITHOUT COOLING	
	STORED	NOT SAVED	SAVED NOT SAVED	
	POLARITY	ACTIVE - CLOSED	ACTIVE - OPEN ACTIVE - CLOSED	
	ACTIVATION	ALWAYS ACTIVE	ALWAYS ACTIVE WITH ENGINE RUNNING	
OUTPUT [33] (427)	FUNCTION	REMOTE STOPPING	<i>See programmable input functions table.</i>	It is possible to associate the input to a function among those listed in the programmable input functions table.
	DELAY	1 sec	0 - 600 sec	Cut-in delay.
	FAULT TEXT	<i>Empty</i>	"0 - Z"	Text displayed when a fault is associated to the input. The text is not translated automatically.
	STOP	FAULT DOES NOT CAUSE A STOP	FAULT CAUSES A STOP FAULT DOES NOT CAUSE A STOP	Settings valid only when a fault is associated to the input.
	COOLING	WITHOUT COOLING	WITH COOLING WITHOUT COOLING	
	STORED	NOT SAVED	SAVED NOT SAVED	
	POLARITY	ACTIVE - CLOSED	ACTIVE - OPEN ACTIVE - CLOSED	
	ACTIVATION	ALWAYS ACTIVE	ALWAYS ACTIVE WITH ENGINE RUNNING	
INPUT [41] (421) [42] (422)	FUNCTION	FAULT	<i>See programmable input functions table.</i>	It is possible to associate the input to a function among those listed in the programmable input functions table.
	DELAY	1 sec	0 - 600 sec	Cut-in delay.
	FAULT TEXT	"FAULT AVAILABLE 1"	"0 - Z"	Text displayed when a fault is associated to the input. The text is not translated automatically.
	STOP	FAULT DOES NOT CAUSE A STOP	FAULT CAUSES A STOP FAULT DOES NOT CAUSE A STOP	Settings valid only when a fault is associated to the input.

	COOLING	WITHOUT COOLING	WITH COOLING
			WITHOUT COOLING
	STORED	NOT SAVED	SAVED
			NOT SAVED
	POLARITY	ACTIVE - CLOSED	ACTIVE - OPEN
			ACTIVE - CLOSED
	ACTIVATION	ALWAYS ACTIVE	ALWAYS ACTIVE
			WITH ENGINE RUNNING
INPUT n MDE-088	The parameters correspond to "Input 41".		

MDE-088: input/output expansion modules.

Here below, the **PROGRAMMABLE INPUT FUNCTIONS TABLE**.

<i>Parameter</i>	<i>Description</i>
----	No function is associated.
FAULT	A fault is associated to the input. All the fault characteristics can be set: text, delay, stop, cooling, memory, polarity and activation.
REMOTE START-UP	Function enabled only in automatic mode. When the contact closes to ground, REMOTE START-UP is shown on the display. After the cut-in delay, the imminent start-up signal is given, and then the start cycle begins. When the contact is open, the genset is stopped.
REMOTE STOPPING	Function enabled only in automatic mode. When the contact closes to ground, REMOTE STOP is shown on the display. After the cut-in delay the control unit will not allow any start-up and if the engine is running it will be stopped.
PROTECTION INHIBITION	When the contact is closed towards ground, the control unit protection devices are inhibited with the exception of those related to overspeed, overfrequency, emergency, maintenance with stops and hire (if this stops).
FAULT RESET	When the contact closes towards ground, the faults are reset in the same way as it is done with the front button.
FAULT SILENCING	When the contact closes towards ground, the general alarm is silenced, in the same way as it is done with the front buttons.

PROGRAMMABLE OUTPUTS

Outputs 6, 19, 70 and 47 and 70 can be associated to various functions or to the faults managed by the control unit. The possible settings are given below:

<i>Parameter</i>	<i>Sub-parameter</i>	<i>Factory settings</i>	<i>Range</i>	<i>Notes</i>
OUTPUT [6]	TYPE	FUNCTION	FUNCTION	It is possible to associate a function or a fault among those listed in the "Programmable Output Functions Table" or the "Programmable Output Faults Table" to the output.
			FAULT	
	EVENT	GLOW PLUGS	<i>See "Programmable Output Functions Table" or "Programmable Output Faults Table".</i>	
OUTPUT [19]	TYPE	FUNCTION	FUNCTION	It is possible to associate a function or a fault among those listed in the "Programmable Output Functions Table" or the "Programmable Output Faults Table" to the output.
			FAULT	
	EVENT	KEY 15/54	<i>See "Programmable Output Functions Table" or "Programmable Output Faults Table".</i>	
OUTPUT [70]	TYPE	FUNCTION	FUNCTION	It is possible to associate a function or a fault among those listed in the "Programmable Output Functions Table" or the "Programmable Output Faults Table" to the output.
			FAULT	
	EVENT	GENERAL ALARM	<i>See "Programmable Output Functions Table" or "Programmable Output Faults Table".</i>	
OUTPUT [47]	TYPE	FUNCTION	FUNCTION	It is possible to associate a function or a fault among those listed in the "Programmable Output Functions Table" or the "Programmable Output Faults Table" to the output.
			FAULT	
	EVENT	GENERAL ALARM	<i>See "Programmable Output Functions Table" or "Programmable Output Faults Table".</i>	
OUTPUT n MDE-088	TYPE	----	FUNCTION	It is possible to associate a function or a fault among those listed in the "Programmable Output Functions Table" or the "Programmable Output Faults Table" to the output.
			FAULT	
	EVENT	----	<i>See "Programmable Output Functions Table" or "Programmable Output Faults Table".</i>	

MDE-088: input/output expansion modules.



Here below, the **PROGRAMMABLE OUTPUT FUNCTIONS TABLE**.

<i>Parameter</i>	<i>Description</i>
----	No function is associated.
KEY 15/54	The "key 15/54" management is associated to the output. The output becomes positive before the engine is started, remains positive while the engine is running and is disabled a few seconds after the control unit has detected that the engine is switched off.
GLOW PLUGS	The glow plug management is associated to the output.
GENERAL ALARM	The general alarm management is associated to the output. It is disabled when the fault is reset or silenced by pressing an arrow.
PETROL STARTER	The "starter" control management for petrol engines is associated to the output.

ENGINE WARM-UP	The engine heating control management is associated to the output.
MOTOR RUNNING	Activates the output and signals that the engine is actually running.
DELAYED ENGINE RUNNING	Signal activated 20 seconds after the engine starts running (cannot be programmed).
AUTOMATIC MODE	Indicates that the control unit is in automatic mode.
MANUAL MODE	Indicates that the control unit is in manual mode.
OFF MODE	Indicates that the control unit is in off mode.
FAULT RESET	Enables the output for 1 second when the operator resets the faults using the functions button.
START-UP IN PROGRESS	Indicates that the control unit is attempting to start up. Reset after the attempts.
AUTOMATIC START	The generator set is running from remote contact.
START-UP TRIGGERED BY AUTOMATIC TEST	The generator set is running due to an automatic test.
MANUAL START	The generator set is running due to a manual start.
GSM START-UP	The generator set is running due to a text message command received from the GSM.
START-UP TRIGGERED BY TIMER	The generator set is running due to a daily timer.
STOP WITH ELECTROMAGNET	The engine stop control management with electromagnet excited during stopping phase is associated to the output.
STOPPING IN PROGRESS	Indicates that the control unit is running the stopping procedure. Restores with the engine stopped or with a "stop failed" signal.
EMERGENCY	Indicates that the control unit is blocked due to an emergency stop.
REMOTE STOPPING	Indicates that the control unit is blocked due to a remote stop.
STOP TRIGGERED BY TIMER	Indicates that the control unit is blocked due to a stop triggered by the daily timer.
FAULTS CAUSING STOPS	Enabling the output, it indicates that faults causing stops have occurred.
FAULTS NOT CAUSING STOPS	Enabling the output, it indicates that faults not causing stops have occurred.
GENSET PARAMETERS OK	The electrical parameters of the generator are correct.

It is possible to associate all the faults managed by the control unit to the programmable outputs. Doing this remotely indicates the presence of any fault that has occurred. See "Fault List".

DEVICE

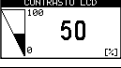
Parameter	Factory settings	Range	Notes
LOGO	ENABLED	ENABLED DISABLED	It is possible to exclude the display of the logo appearing when the control unit is switched on.
SETUP RESET			It is possible to restore all default settings. 
LCD BRIGHTNESS	100 %	(0 ÷ 100) %	The brightness of the LCD display can be changed. 
LCD CONTRAST	50 %	(0 ÷ 100) %	It is possible to modify the LCD display contrast. 
REGISTRATION	Empty	"000000000" ÷ "999999999"	It is possible to program an alphanumeric serial code in the control unit. This number is displayed every time the control unit is switched on, and can be read in the INFORMATION menu. It is saved in the non volatile memory.
CLIENT LOGOS-LANGUAGE			Reserved for Elcos technicians. Accessing this function, you can check that the client memory area storing the programmable language and logos is correct..

PASSWORD

Access to technical settings is password activated. There are 7 password levels, each level gives access to different settings. The factory password 7 (DEVICE) is "2015" and all the others are "0000". The list of the 7 levels is given below:

1. The operator can read all the settings but cannot edit them.
2. Access in reading and editing mode to maintenance and rental hours and the log.
3. Access only for resetting expired maintenance.
4. Access only for resetting expired rental blocks and for GSM block.
5. The operator can read and edit all settings.
6. Access in reading and editing mode to total operating hours.
7. Access to the device menu.

For example: if we wish to prevent the operator from modifying the total operating hours, we must set a different password to "0000" in level 6, for example "1234". Doing this, we can enter the technical settings using the default password ("0000"), but will not have access to the operating hours. To access the operating hours menu we must enter the password "1234".

Parameter	Factory settings	Range	Notes
-----------	------------------	-------	-------

PASSWORD 1	"0000"	"0000" ÷ "9999"	The operator can read all the settings but cannot edit them.
PASSWORD 2	"0000"	"0000" ÷ "9999"	Access in reading and editing mode to maintenance and rental hours and the log.
PASSWORD 3	"0000"	"0000" ÷ "9999"	Access only for resetting expired maintenance.
PASSWORD 4	"0000"	"0000" ÷ "9999"	Access only for resetting expired rental blocks and for GSM block.
PASSWORD 5	"0000"	"0000" ÷ "9999"	The operator can read and edit all settings with the exception of the total working hours.
PASSWORD 6	"0000"	"0000" ÷ "9999"	Access in reading and editing mode to total working hours.
PASSWORD 7	"2015"	"0000" ÷ "9999"	Access to the "DEVICE" menu.

FAULT LIST

The complete list of faults managed by the control unit is given below.

Fault code	Description	Occurs when:
111	MAINTENANCE 1	Maintenance 1 expired.
112	MAINTENANCE 2	Maintenance 2 expired.
113	MAINTENANCE 3	Maintenance 3 expired.
114	CYCLICAL MAINTENANCE	Programmed maintenance expired.
115	RENTAL HOURS	The rental hours have expired.
120	BATTERY UNDERVOLTAGE	The battery voltage is lower than the set threshold.
121	BATTERY OVERVOLTAGE	The battery voltage is higher than the set threshold.
122	ENGINE LOW TEMPERATURE	The engine has not reached the set temperature.
123	OVERTEMPERATURE PRE-ALARM	The engine has exceeded the overtemperature pre-alarm threshold.
124	PRE-ALARM	The engine has exceeded the overtemperature threshold read by the transmitter.
125	THERMOSTAT OVERTEMPERATURE	The engine thermostat has cut in.
129	FUEL RESERVE	The fuel level is lower than the reserve threshold.
130	NO FUEL	The fuel level is lower than the set threshold.
131	LOW OIL PRESSURE PRE-ALARM	The engine oil pressure does not exceed the set threshold.
132	LOW OIL PRESSURE	The engine oil pressure switch has cut in.
133	STOPPING FAILURE	Detects that engine is running even if the stopping system has been activated.
135	LOW RADIATOR LEVEL	Insufficient radiator coolant.
136	CHARGING ALTERNATOR	The output "D+" or "W" on the charging alternator does not work.
137	STARTING FAILURE	The control unit has attempted to start the generator, but the engine is not running.
139	OVERSPEED	The RPMs detected by the control unit have exceeded the set threshold.
140	FUEL FLOAT INTERRUPTED	The electrical circuit for the fuel float is interrupted.
141	OIL PRESSURE SWITCH FAULT	The oil pressure switch contact is open with the engine switched off.
220	GENERATOR UNDERVOLTAGE	The generator voltage is lower than the set threshold.
221	GENERATOR OVERPOWER	The power absorbed by the generator has exceeded the alarm threshold.
222	GENERATOR OVERVOLTAGE	The generator voltage is higher than the set threshold.
223	GENERATOR UNDERFREQUENCY	The generator Hz value is lower than the set threshold.
224	GENERATOR OVERFREQUENCY	The generator Hz value is higher than the set threshold.
225	GENERATOR OVERLOAD PRE-ALARM	The current absorbed by the generator has exceeded the pre-alarm threshold.
226	GENERATOR OVERLOAD	The current absorbed by the generator has exceeded the alarm threshold.
227	GENERATOR NOT DELIVERING	Although running, the generator does not deliver voltage.
230	GENERATOR PHASE SEQUENCE	The sequence of the three generator phases is not correct.
231	GENERATOR ASYMMETRY	The voltages between the three generator phases are not similar.
419	EMERGENCY STOP	The emergency button has been pressed.
421	AVAILABLE FAULT 41	The fault associated with programmable input 41 has occurred.
422	AVAILABLE FAULT 42	The fault associated with programmable input 42 has occurred.
423	AVAILABLE FAULT 46	The fault associated with programmable input 46 has occurred.
426	AVAILABLE FAULT 32	The fault associated with programmable input 32 has occurred.
427	AVAILABLE FAULT 33	The fault associated with programmable input 33 has occurred.
430	CAN BUS	The control unit does not receive data from the CAN Bus line.
431	ENGINE CONTROL UNIT	Engine fault detected by the electronic control unit (ECU).
443	FUEL FLOAT TABLE ERROR	The float table has been programmed with errors.
446	OIL PRESSURE TRANSMITTER TABLE ERROR	The oil pressure transmitter table has been programmed with errors.
447	TEMPERATURE TRANSMITTER TABLE ERROR	The temperature transmitter table has been programmed with errors.
449	KEYBOARD ERROR	The control unit turns on with at least one button pressed.
500	NO GSM MODEM	The GSM modem does not communicate with the control unit.
501	SIM NOT INSTALLED	There is no SIM card installed in the GSM modem.
502	SIM BLOCKED	The PIN code of the SIM Card installed in the modem is active.
503	GSM CODE ERROR	The GSM modem has detected a coded error.
504	GENERIC GSM ERROR	The GSM modem has detected a non-coded error.
506	I/O EXP. 1 FAULT	The input/output expansion module does not respond to the data request.
507	I/O EXP. 2 FAULT	The input/output expansion module does not respond to the data request.
508	I/O EXP. 3 FAULT	The input/output expansion module does not respond to the data request.
509	I/O EXP. 4 FAULT	The input/output expansion module does not respond to the data request.
556	BLOCK VIA GSM	The control unit is blocked by a text message command.
558	REMOTE PANEL DOES NOT COM-MUNICATE	The remote panel connected does not communicate with the control unit.
-	MDE-088 [01 – 32]	The error associated to I/O module programmable input has occurred.
-	EEPROM ERROR	Failed access to the static memory.

TECHNICAL SPECIFICATIONS

Power supply [1], [2]			
Suitable for batteries	12 Vdc	24 Vdc	
Operating range	(8 ÷ 48) Vdc		
Absorption with engine not running	130 mA @ 12 Vdc	90 mA @ 24 Vdc	
Absorption in stand-by	10 mA @ 12 Vdc	7 mA @ 24 Vdc	
Absorption with contact open at terminal 45	0 A		
Voltage dip on battery power supply	From 10 Vdc to 0 Vdc for 20 ms		
Digital inputs [30], [32], [33], [41], [42], [51], [52],			
Type of input	Negative		
Maximum current supplied	4 mA		
Voltage threshold for low signal	≤ 0,6 Vdc		
Voltage threshold for high signal	≥ 1 Vdc		
Digital inputs [4]			
Type of input	Positive		
Maximum current absorbed	0,6 mA @ 48 Vdc		
Voltage threshold for low signal	≤ 2 Vdc		
Voltage threshold for high signal	≥ 2 Vdc		
Digital inputs [45], [46]			
Type of input	Positive		
Maximum current absorbed	4 mA @ 48 Vdc		
Voltage threshold for low signal	≤ 1,7 Vdc		
Voltage threshold for high signal	≥ 2 Vdc		
Terminal input [65]			
AC voltage	(5,5 ÷ 65) Vac		
Measurement range	(50 ÷ 1500) Hz		
Terminal input [66]			
Applicable voltage	(0,5 ÷ 30) Vdc		
Pick-up input terminals [63 - 64]			
AC voltage	(0,5 ÷ 5,5) Vac		
Measurement range	(100 ÷ 15000) Hz		
Minimum pick-up impedance	> 400 Ω		
Generator voltmetric inputs [95], [96], [97], [98]			
Dielectric strength voltage between battery voltage circuits and generator voltage circuits	3750 Vac 50 Hz 1 sec		
Rated insulation voltage	Genset voltage terminal	600 Vac	
	Battery voltage terminal	48 Vac	
Insulation class	1		
Measurement range	(80 ÷ 570) Vac three-phase	(45 ÷ 340) Vac single-phase	
Accuracy	±1 %		
Frequency meter generator			
Measurement range	(45 ÷ 85) Hz		
Accuracy	±0,1 Hz		
Amperometric inputs [75], [76], [77], [78]			
Measurement range	20 mA ÷ 6 Aac		
Ammeter transformer ratio	/5		
Maximum displayable current	4800 Aac		
Accuracy	±1 %		
Digital outputs [6], [19], [47], [70]			
Type of output	Positive, closes on terminal [1]		
Maximum load	0,25 A		
Digital outputs [15], [17]			
Type of output	Positive, closes on terminal [4A]		
Maximum load	Terminal 15	0,25 A	
	Terminal 17	1,5 A	
Digital outputs [48 - 49]			
Type of output	Clean contact		
Maximum applicable voltage	48 Vdc, 65 Vac		
Maximum load	0,25 A		
Outputs [73 - 74]			
Type of output	Clean contact		
Maximum applicable voltage	275 Vac		
Maximum load	3 A		
Displayed powers (kW, kVAR, kVA, kWh)			
Accuracy	±2 %		
Maximum displayable current	3300 kVA		
Engine instruments [37], [57], [58]			
Oil pressure	(0 ÷ 380) Ω	(0,0 ÷ 9,0) BAR	(0 ÷ 900) kPa
Temperature	(0 ÷ 3200) Ω	(0 ÷ 140) °C	(0 ÷ 284) °F

Fuel level	(0 ÷ 380) Ω	(0 ÷ 100) %
Accuracy (pressure gauge, thermometer, fuel level)		± 2 %
Lines of communication		
RS485 1, 2, 3 (No optoisolator)	Baud-rate	(1200 ÷ 115200) bps
	Parity	None/even
USB 2.0 (Type B)	Interface	Not isolated. Maximum cable length 3 m.
CAN Bus (Non optoisolata)	Baud-rate	250 kbps
	Protocol	SAE J1939
Environmental conditions		
Operating temperature		(-20 ÷ 60) °C
Storage temperature		(-20 ÷ 60) °C
Relative humidity		≤ 80 %
Protection class		
Back		IP 20
Front		IP 54
Container		
Weight		480 g
Dimensions (LxHxW)		(157 x 109 x 74) mm
Perforations		(137 x 88) mm
Material		PC/ABS V0
Terminals [1], [2], [4A], [73], [74], [75], [76], [77], [78], [95], [96], [97], [98]		
Screw		M3
Nominal wire size		2,5 mm ²
Terminals (remaining ones)		
Screw		M2
Nominal wire size		1 mm ²
Installation		
Built-in		
4 nuts		M4
Nut tightening torque		(1,0 ÷ 1,5) Nm

WARNING

Performs only genset control and command functions. Controls the generator contactor for user power supply. It is designed solely to be built into an electrical panel and connected to the other components (contactors, fuses, thermal magnetic switches, etc.) the installer has arranged to complete the system.

Warning: Parts powered with dangerous voltages



The control unit can only be accessed by specifically assigned, duly trained personnel. Maintenance operations cannot be performed unless the system is disconnected from the generator and the battery. As an additional protection measure, we recommend grounding the system phases. Notwithstanding the above, only specifically assigned, duly trained personnel can perform the following operations with the system powered:

- visual inspection of control unit connections and markings;
- taking voltage and/or current measurements.

These jobs must always be performed using equipment that ensures appropriate electrical protection.

Warning: Compliance with the following recommendations is obligatory



- Always make connections following the wiring diagram provided in the manual.
- Any work performed on the unit must be carried out with the engine off and with starter motor terminal 50 disconnected.
- Check the consumption of the connected devices is in line with the described technical specifications.
- The installation must always guarantee adequate dissipation of heat.
- Always install the device at a lower position than any other devices that produce or dissipate heat.
- Handle and connect without exposing the electronic circuit board to mechanical strain.
- Do not let cuttings of copper conductors or other metal residues drop onto the control unit.
- Never disconnect the battery terminals while the engine is running.
- Strictly avoid using a battery charger for emergency start-up; this could damage the control unit.
- To safeguard persons and equipment, always disconnect the electrical system terminals from the battery poles before connecting an external battery charger.

Device sensitive to electrostatic discharge



Do not open the rear cover unless precautions to avoid electrostatic discharges have been taken.

This control unit is not suitable for operation under the following conditions:



- Where the room temperatures exceeds the limits specified in the technical data sheet.
- Where abrupt shifts in temperature and air pressure produce exceptional condensation.
- Where there is high pollution caused by dust, fumes, vapour, salts and corrosive or radioactive particles.
- There is high radiation of heat due to direct sunlight, ovens or the like.
- You suspect the presence of mould or pests.
- There is a danger of fire or explosion.
- Strong shocks or vibrations can be transmitted to the control unit.
- The control unit is protected by barriers or casings with a protection rating below IP40.

Electromagnetic Compatibility

This control unit works correctly only if it is installed in systems that comply with regulations governing CE or UKCA marking; in fact, it complies with the immunity requirements given in EN61326-1, but this does not rule out the possibility that malfunctions could occur in extreme cases that may arise in particular situations.

The installer is responsible for checking that the disturbance level does not exceed the level specified by regulations.

Operation and maintenance



We recommend the following maintenance on a weekly basis:

- checking the signals;
- checking the battery status;
- checking the wires are connected firmly and the condition of the terminals.

INFORMATION FOR ORDERING

Type	Item Code
CAM-130-10	00242346

STANDARD ACCESSORIES

Type	Item Code
KIT MU CAM-130-10	40804489

ACCESSORIES AVAILABLE ON REQUEST

Type	Item Code
EXPANSION MODULE MDE-088	00242269
ETHERNET INTERFACE ZE-100	00070227

ZW-SMART programming software	00070212
-------------------------------	----------

DOCUMENTATION ON REQUEST

Downloadable from the website www.elcos.it/

	Diagram number
Petrol engine diagram	00000741
Connection diagram with expansion modules	00000744
Connection diagram with voltage transformers	00000745

List of MOD Bus CAM-130-10 addresses

CONFORMITY

