

CAM-335-10

Developed to equip automatic emergency panels.

It controls and operates genset, connecting the power user to the mains or generator.

USER'S MANUAL

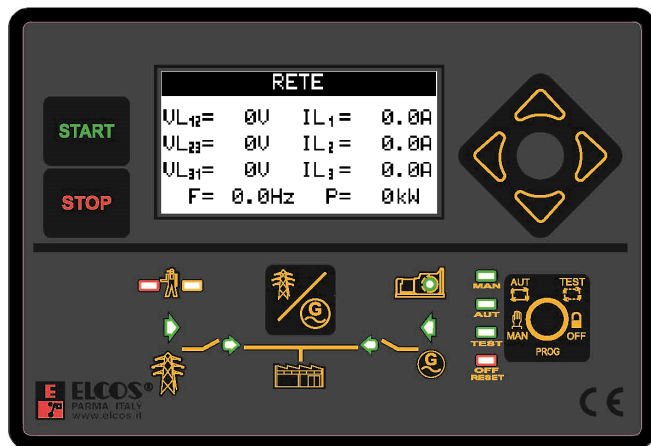

Complete with backlit graphic display to view:

- Three voltmeters for the mains.
- Three voltmeters for the generator.
- Three mains/generator ammeters.
- Mains/generator frequency meter.
- Generator tachometer.
- Mains/generator kW (active), kVAR (reactive) and kVA (apparent) powers.
- Battery voltmeter.
- Fuel level gauge.
- Water/oil thermometer.
- Oil pressure gauge.
- Total hour-meter.
- Partial hour-meter.
- Start-ups counter.

Functions:

- Automatic monitoring of faults with display messages.
- Complete three-phase voltmetric control of mains and genset (undervoltage, overvoltage, phase asymmetry, incorrect phase sequence, underfrequency and overfrequency).
- Texts in 7 languages: Italian, English, French, German, Spanish, Portuguese and a programmable language.
- CAN Bus Connection SAEJ1939.
- RS232, RS485 serial ports and USB.
- MOD Bus RTU Protocol.
- 4-maintenance management.
- Management of rental hours.
- Remote controls (start, stop, EJP).
- Generator start and stop on power demand.
- Ability to start generator when the battery charge is low.
- Option of associating inputs and outputs with different functions.
- Glow plug preheating management.
- Management of refuelling of working tank from storage tank.
- Clock for programming genset starting or stopping.
- Automatic test.
- Anomaly log.
- Option of password protected programming.
- Dimensions (LxHxW) 157x109x74mm



Tel. +39 0521/772021

E-mail: info@elcos.it – <https://www.elcos.it>

CONTENTS

GENSET CONTROL UNIT	1
CONTENTS.....	2
CHRONOLOGY OF MANUAL REVISIONS	3
INSTRUCTIONS IN BRIEF	4
INSTRUMENTS	4
DISPLAY	5
OPERATION	6
FUNCTION SELECTION.....	6
MANUAL.....	6
AUTOMATIC.....	6
TEST.....	6
OFF.....	6
PROGRAMMABLE OUTPUTS.....	7
GLOW PLUG PREHEATING.....	7
ENGINE TYPES	7
AUTOMATIC TEST	7
ENGINE RUNNING DETECTION.....	7
STOPPING SYSTEMS	7
EMERGENCY STOP.....	7
GENERAL ALARM	8
GENSET AND USER PROTECTIONS.....	8
PREVENTIVE MAINTENANCE.....	8
RENTAL FUNCTION	8
STARTING GENSET WITH LOW BATTERY	8
START ON POWER REQUEST	8
DAILY STARTING-STOPPING	8
CALL INPUT (TERMINAL 30).....	8
START INPUT (TERMINAL 32).....	9
STOP INPUT (TERMINAL 33).....	9
PROGRAMMABLE INPUTS (TERMINALS 41 AND 42)	9
MESSAGES AND CAN BUS INSTRUMENTS	9
ENGINE HEATING	9
EJP FUNCTION.....	10
VOLTMETRIC CONNECTIONS.....	10
MAINS/GENERATOR VOLTMETRIC RELAYS	10
FUEL FILLING MANAGEMENT	10
FICTITIOUS LOAD MANAGEMENT	11
IMMINENT START WARNING	11
PASSWORD.....	11
SERIAL NUMBER (ID).....	11
SERIAL PORTS.....	11
SIGNAL LAMPS FOR HATZ STAGE V ENGINES	12
ECU READINGS	12
MANAGEMENT OF EMISSIONS REDUCTION DEVICES	13
HOURS TO NEXT SERVICE COUNTER.....	13
CONNECTION DIAGRAM	14
USER PROGRAMMING	16
FAULT LIST	19
TECHNICAL SPECIFICATIONS.....	20
WARNING	21
INFORMATION FOR ORDERING	22
STANDARD ACCESSORIES	22
ACCESSORIES AVAILABLE ON REQUEST.....	22
DOCUMENTATION ON REQUEST.....	22
DECLARATION OF CONFORMITY	22

CHRONOLOGY OF MANUAL REVISIONS

<i>Date</i>	<i>Revision</i>	<i>Description</i>	<i>Page</i>
27/07/2015	1.00	First release	
05/09/2016	1.05	MAX mains voltage present delay =9999 sec.	12 technical prog.
10/10/2016	1.06	Fault: radiator stops without cooling	8 technical prog.
19/12/2016	1.09	Semi-automatic mode, reset of maintenance cycle, acceptance of commands via SMS from any telephone number.	6, 16, 18 technical prog.
23/05/2017	1.10	<ul style="list-style-type: none"> • Exclusion of current transformers • Programming of maximum number of fault SMS messages • Keyboard error input • Programmable mains contactor fault input • Programmable genset contactor fault input 	5,12,18, 20 Technical prog.
	1.13	<ul style="list-style-type: none"> • Change automatic test 	1, 7, 3, 13 Technical prog.
22/11/2019	1.13	<ul style="list-style-type: none"> • Replacing ZW-100-PR with ZW-SMART • Added vibration test 	
04/06/2020	1.14	<ul style="list-style-type: none"> • Time synchronization of other control units. 	
19/04/2024	1.30	<ul style="list-style-type: none"> • Hatz Stage V engine management added 	
08/01/2025	2.00	CAM-335-10 model.	

INSTRUCTIONS IN BRIEF

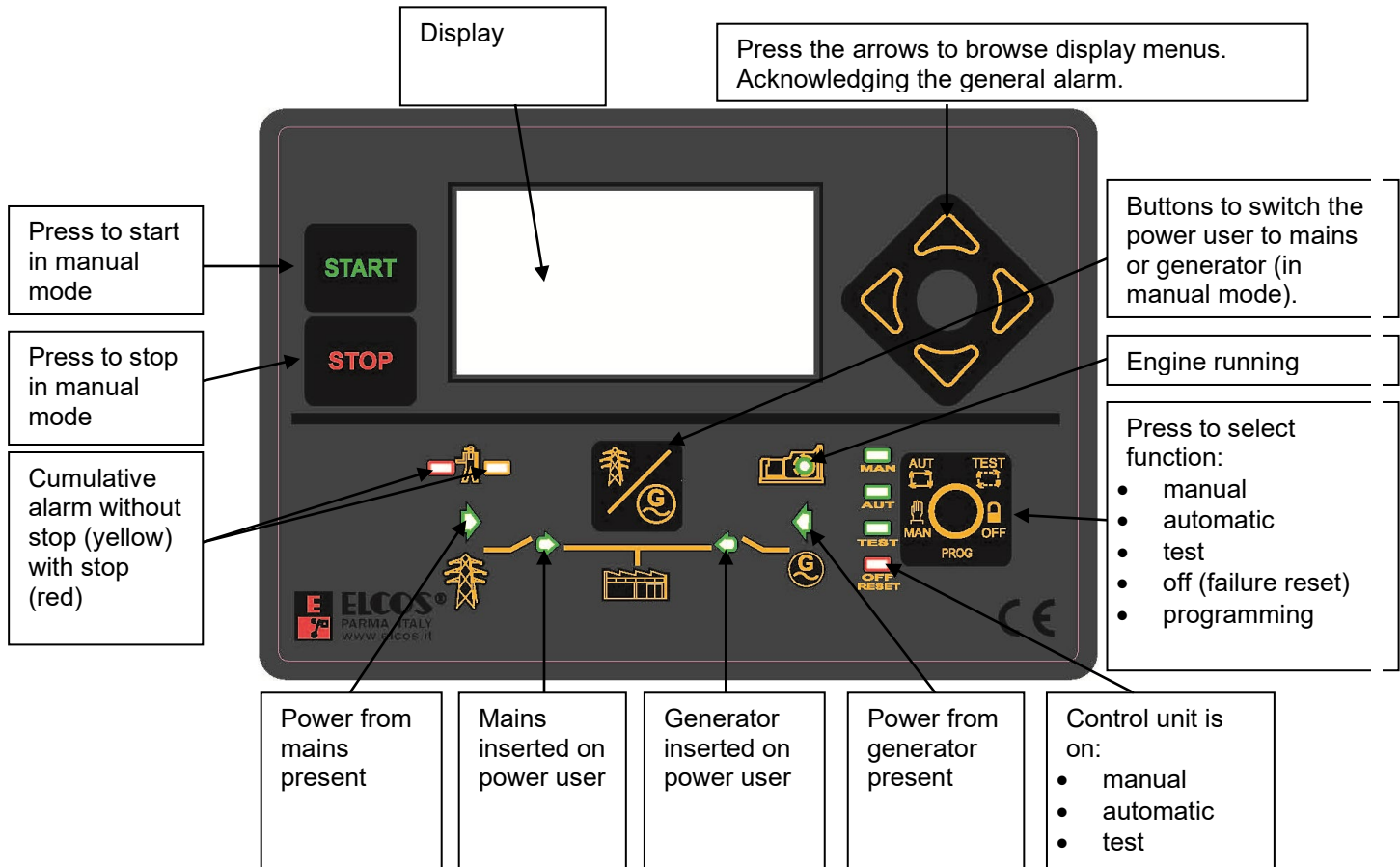

INSTRUMENTS

The control unit has a backlit 128 x 64 dot graphic display. It is used to view the following instruments:

- Three line-to-line mains/generator voltages.
- Three star mains/generator voltages.
- Three mains/generator ammeters.
- Mains/generator frequency meter.
- Active (kW), reactive (kVAR) and apparent (kVA) power, for both mains and generator. The powers are displayed for each phase and as a sum of the phases.
- Mains/generator power factor indicator displayed for each phase.
- Mains/generator energy counter (kWh).
- Battery voltage.
- D+ voltage (pre-excitation alternator).
- Fuel tank level indicator.
- Engine temperature expressed in °C or °F.
- Oil pressure expressed in BAR or kPa.
- Engine revolutions (RPM).
- Total hour-meter.
- Partial hour-meter.
- Start-ups count.
- Starting failure counter.
- Maintenance expirations.
- Rental hours expirations.
- Calendar clock.
- Automatic test.



All the instruments for the mains (V, A, Hz and kW) are also displayed simultaneously. Simply pressing the arrows displays all electrical instruments for the generator and engine. In the event of an anomaly, the display presents the message indicating the anomaly that has occurred.

DISPLAY

The instruments displayed on the control unit are divided into groups. The groups are:



- Mains
- Generator
- Engine instruments
- CAN Bus instruments (if CAN Bus connection is enabled)
- Counters
- Maintenance (if maintenance hours have been set)
- Rental (if rental hours have been set)
- Fuel top-up management (if function is enabled)
- Anomalies
- Clock
- Information about the control unit.

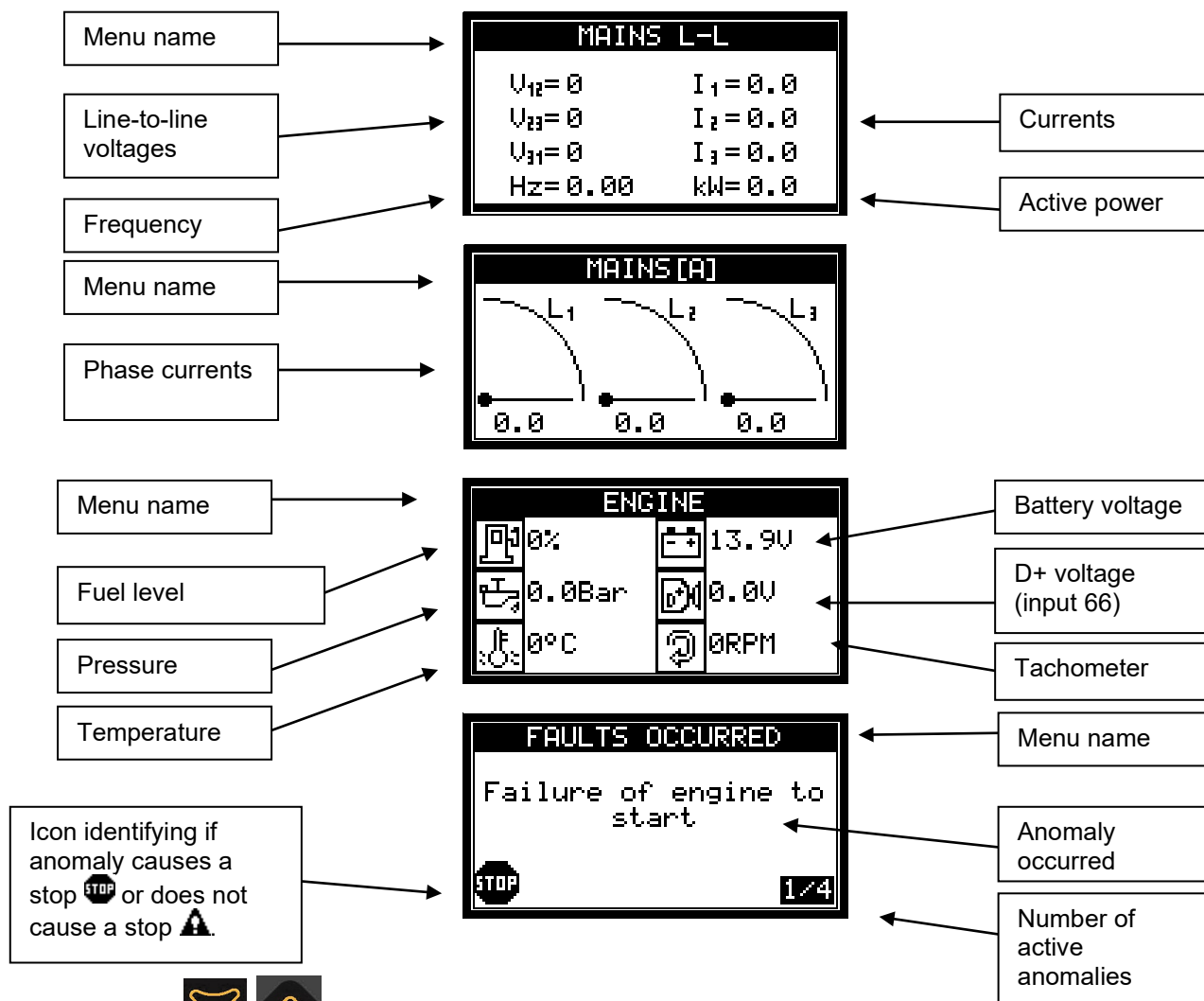

The two arrows   are used to scroll through the instrument groups on the display or to select the sub-menus under the settings.

The following are a few examples of instrument display menus.



The two arrows   are used to move within the instrument groups or to scroll through the choices in the settings menus.

OPERATION

FUNCTION SELECTION



The function selected using the key is indicated by its light which goes on.

MANUAL



Image displayed when switched to manual.

Press **START** to start and **STOP** to stop (a quick press is sufficient).

Pressing the  button switches the load from the mains to the generator and vice versa.

In manual mode, the generator protection function can be programmed in two ways:

- Display the fault recorded and stop the engine (this is the default setting).
- Only display the fault recorded, without stopping the engine. Generator overspeed and emergency anomalies are programmed to shut down the engine; they cannot be programmed without engine shutdown.

AUTOMATIC



Image displayed when switched to automatic.

When a mains anomaly occurs — detected by the internal voltage relay inside the control unit or when the external call delay has elapsed — the control unit commands the mains contactor to open and the genset to start. With the engine running and with correct generator voltage and frequency, once the G.S. VOLTAGE PRESENT DELAY has elapsed, the generator contactor is closed. When operating, the genset is protected from any anomalies. When the mains voltage is restored and the MAINS VOLTAGE PRESENT DELAY has elapsed, the control unit commands the generator contactor to open and after the GENERATOR MAINS INTERLOCK time has elapsed, the mains contactor closes.

The COOLING TIME enables and facilitates subsequent engine cooling before it shuts down.

To facilitate start-up, a special circuit determines a series of start-up attempts, the number, pause duration and start-up duration of which can be programmed. If running of the entire series of start-up attempts is unable to start the engine, when the cycle is completed, STARTING FAILURE is displayed and the stop cycle starts.

TEST



Image displayed when switched to test.

In testing, the engine start-up cycle is obtained as in automatic mode, with the exception that the user remains powered from the mains. If, during the test, a mains anomaly occurs, the control unit remains in test mode but commands the generator contactor to close.

OFF

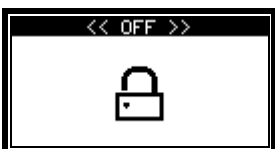

Image displayed when switched to off. When set to OFF, the engine cannot be started in any way and, if it is running, it stops without the engine cooling step.

PROGRAMMABLE OUTPUTS

WARNING!

Outputs 6, 19 and 70 can be associated to many functions (see programming manual under the section "PROGRAMMABLE OUTPUTS"). **It is NOT possible to simultaneously associate more than one function to an output.** For example, if fuel filling is associated to output 70, it is not possible to manage the general alarm from this terminal and vice-versa. By default, management of glow plugs is associated to output 6, the signal that simulates the 15/54 to output 19, and the general alarm to output 70.

GLOW PLUG PREHEATING

Activation of the glow plug output is adjustable — from a minimum of 0 seconds (command off) to a maximum of 60 seconds — for both automatic and manual mode. Once activation has been completed, the engine start-up procedure begins. Glow plug post-heating can also be managed, i.e. maintaining output live for a set amount of time, even after the engine has been started (see programming manual).

ENGINE TYPES

The control unit can manage start-up of both diesel and petrol engines. Diesel engines allow for the connection of the CAN bus line to the control units with electronic injection. For choice of engines, see the programming manual.

AUTOMATIC TEST

The automatic test is enabled only with the control unit on automatic. During the test, the generator set starts up and stays running for the AUTOMATIC TEST DURATION time (programmed at 3 minutes). If a mains anomaly occurs, the generator contactor closes. The display shows AUTOMATIC TEST during the test cycle. You can also choose whether to run a commutation or not during the test (default setting: no commutation). Press STOP to stop the engine during the test. The test will not be run if there is an anomaly. The automatic test can be performed in two ways:

- WEEKLY: the test will be run weekly at the time and on the day set.
- MEASURED: the test can be programmed to run at cycles ranging from 1 to 30 days. The default setting is 7 days. To enable the test, just enter User Programming and include the function. Once any one of the test parameters has been set, it starts for the first time when one minute after quitting the setting mode has elapsed. If at that time the conditions for starting the test are not present (e.g. because the control unit is not on automatic), the test will be run at the next deadline. The time count starts all over again when the control unit is reset.

ENGINE RUNNING DETECTION

Engine running is detected by revealing the residual generator frequency and voltage and by detecting the voltage and frequency of the battery charger alternator (permanent or pre-excitation magnets). When an engine with electronic management is connected to the control unit, detection of the running engine occurs when the RPM read by the CAN Bus line exceed the RUNNING ENGINE THRESHOLD RPM. Once detected, the starter motor switches off

and the green LED lights up 

STOPPING SYSTEMS

Stopping can be achieved in two ways:

- With the electromagnet or solenoid valve energized when the engine is running and de-energized when the engine is stopped (default setting).
- With the electromagnet de-energized when engine is running and energized when it is stopped, remaining in this condition for the entire STOPPING TIME after engine not running has been detected.

If, after 120 seconds from receipt of the stop command, the control still detects the engine running signal, the STOPPING FAILURE trips.

EMERGENCY STOP

This is available in all operating modes. It is possible to install (hook mount) one or more buttons. Stopping is immediate, without engine cooling; it activates the general alarm and EMERGENCY STOP is displayed.





Do not use the emergency button in combination with a stopping system that is not energized while running.

GENERAL ALARM

The general alarm can be obtained by installing a signal at the appropriate alarm terminal. It can be programmed so that it is always on or remains on for a specific amount of time. It trips whenever the control unit detects an anomaly. Pressing one of the arrows  silences the alarm.



GENSET AND USER PROTECTIONS

Tripping of an anomaly is shown on the display and can cause the engine to cut out and activates the general alarm. See the FAULT LIST table on page 17.

Normally the display shows the genset instruments; in the event of an anomaly, it displays the anomaly message triggered. If the anomaly causes a stop, the red LED flashes and the  icon lights up; if the anomaly does not cause a stop, the yellow LED flashes and the  icon lights up

If the anomalies are detected by the CAN Bus line connected to the engine's electronic injection control unit, the yellow and red LEDs light up and remain steady on.

Press the ARROW to review the instruments on the display and, at the same time, silence the general alarm, use one of the 4  navigational arrows. After 20 seconds have elapsed since the last time the key was pressed, the display reverts back to displaying the anomaly/anomalies that have occurred.

When OFF RESET lights up, the anomalies can be reset by pressing the key . If the OFF function is disabled, press the  key to reset the anomalies.

PREVENTIVE MAINTENANCE

When preventive maintenance operations are to be carried out, the flashing alarm light  goes on and the maintenance number that intervened is displayed along with the description set beforehand. If programmed, stopping is also achieved with PROTECTION IN MANUAL bypassed and with the PROTECTION INHIBITION input active. The procedure for resetting expired maintenance is to be performed only by genset manufacturer.

RENTAL FUNCTION

It is possible to programme the number of genset rental hours; after this time has elapsed, the control unit can immediately block genset operation or can block it at the next start-up. If programmed, stopping is also achieved with PROTECTION IN MANUAL bypassed and with the PROTECTION INHIBITION input active. Rental hours are counted down when the engine is running.

STARTING GENSET WITH LOW BATTERY

When the battery is low, the genset can only be started up in automatic mode. When the voltage measured at the battery terminals is below the minimum threshold, the engine will start and remain running until the maximum threshold has been exceeded and the programmable delay time has elapsed.

START ON POWER REQUEST

The genset can only be started up on power request function when in automatic mode. When the power absorbed by the power user is higher than the set threshold for the whole duration of the cut-in delay, the control unit starts the generator set and switches the user to the generator. When the power absorbed by the power user is lower than the set threshold for the whole duration of the cut-in delay, the control unit stops the generator set and switches the user to the generator.

DAILY STARTING-STOPPING

The functions managed by the control unit's internal clock are only active in automatic mode. Up to 10 genset starts can be programmed, with relative switching of the power user to the generator at certain daily time slots. It is also possible to program a genset lockout at a certain daily time slot.

CALL INPUT (TERMINAL 30)

Call input is active with control unit in automatic and test modes. When the contact closes to ground, operation is the same as that of a mains failure.

START INPUT (terminal 32)

The start input is active with control unit in automatic mode. When the contact closes to ground, REMOTE START is shown on the display. When the REMOTE START DELAY time elapses, operation is the same as that of a mains failure. When the start contact opens, operation is the same as when the mains power is restored. Other functions can be associated to this input; see the programming manual.

STOP INPUT (TERMINAL 33)

The stop input is active with control unit in automatic mode. When the contact closes to ground, REMOTE STOP is shown on the display. The control unit does not permit any start-up and, if the genset is running, it stops. Other functions can be associated to this input; see the programming manual.

PROGRAMMABLE INPUTS (TERMINALS 41 and 42)

Inputs 41 and 42 are completely programmable (see the programming manual). The following settings are possible:

Function, Text, Intervention delay, Stop, Cooling, Storage, Polarity, Activation.

MESSAGES AND CAN BUS INSTRUMENTS

Every message or instrument appearing on the display having to do with the injection control unit and read by the CAN Bus line can be identified by the characters [ECU] shown in the lower right corner.

- Anomaly messages are shown on the display as SPN, FMI and OC: SPN is a number identifying a particular component of the diesel engine; FMI is a number identifying the failure or malfunction of the SPN component; OC identifies the number of times this particular problem occurred in the engine.
- If CAN Bus line connection between the two control units is interrupted, the message CAN Bus ANOMALY will appear.
- The instruments managed and displayed by the CAM-335 control unit are:

Instrument	Description	U.M.	
Tachometer	Engine revolutions.	RPM	
Oil pressure	Engine oil pressure.	BAR	kPa
Engine temperature	Engine water or oil temperature.	°C	°F
Fuel consumption	Amount of fuel consumed by the engine per unit of time.	l/h	
Fuel temperature	Fuel temperature at injector inlet.	°C	°F
Turbo temperature	Temperature of turbo compressor oil.	°C	°F
Oil temperature	Temperature of engine oil.	°C	°F
Intercooler temperature	Temperature of fluid in the intercooler downstream the turbo compressor.	°C	°F
Intake temperature	Temperature of pre-combustion air.	°C	°F
Coolant level	Coolant level.	%	
Fuel pressure	Pressure of the fuel between the fuel pump and the injection pump.	BAR	kPa
Coolant pressure	Pressure of coolant in the cooling system.	BAR	kPa
Engine torque	Engine output torque percentage.	Nm	
Engine power	Power developed by the engine.	kW	
Fuel level	Indicates fuel level	%	
Oil level	Level of oil in the engine.	%	
Soot level	DPF clogging percentage.	%	

Electronic engines currently managed are: John Deere, Perkins, Scania, Volvo, Deutz, FPT, VM, Cummins, MTU and Hatz Stage V.

ENGINE HEATING

Function can be activated in SCANIA engines with CAN Bus connection. It warms up the engine at idling speed after it starts. The function takes both engine temperature and set time into account. When the engine reaches the set temperature or set time, the control unit speeds up the engine to rated speed. This default function is disabled. See the programming manual for instructions on how to set the temperature threshold and time. Heating can also be managed for mechanical engines by activating the function in a programmable output and connecting an electromagnet to the engine.

EJP FUNCTION

To activate the EJP function, see the programming manual. It is only active in automatic mode. When the contact connected to terminal 32 closes to ground, EJP STARTUP is shown on the display. After the EJP STARTING DELAY has elapsed (set to 25 minutes), the start-up cycle begins. When the contact connected to terminal 33 closes to ground, EJP SWITCHING CONSENT is shown on the display and operation is the same as that of a mains failure. When the two contacts open, operation is the same as when mains power is restored.

VOLTMETRIC CONNECTIONS

The control unit can be configured to manage THREE-PHASE, TWO-PHASE and SINGLE-PHASE voltages. This selection is valid both for the mains and for the generator; therefore, it is possible to manage, for example, three-phase voltage from the mains and two-phase from the generator. When the mains power is three-phase, the phases must be connected to terminals 91, 92 and 93 and the neutral to terminal 90. With two-phase connection, terminals 91 and 92 must be connected and the neutral must not be connected. Instead, with the single-phase connection, the phase must be connected to terminal 92 and the neutral to terminal 90. Likewise, when the generator power is three-phase, the phases must be connected to terminals 96, 97 and 98 and the neutral to terminal 95. With two-phase connection, terminals 96 and 97 must be connected and the neutral must not be connected. Instead, with the single-phase connection, the phase must be connected to terminal 97 and the neutral to terminal 95.

MAINS/GENERATOR VOLTMETRIC RELAYS

The voltmeter relays are located inside the control unit and serve to control the mains and genset voltages and frequencies. The parameters considered are: power failure, undervoltage, overvoltage, asymmetrical voltages, incorrect phase sequence, under-frequency and overfrequency.

- Mains voltmeter relay: when each parameter has been accepted individually, after the mains voltage present delay has elapsed (programmed to 100 seconds), if the genset is running, it stops and the mains contactor is energized.
- Generator voltmeter relay: when each parameter has been accepted individually, after the generator voltage present delay has elapsed (programmed to 7 seconds), the generator contactor closes. It takes just one parameter outside the normal range to de-energize the generator contactor.

FUEL FILLING MANAGEMENT

When the automatic fuel filling function is enabled, a dedicated menu is displayed. With filling, the fuel is transferred from a storage tank to the genset tank. By pressing the UP arrow button, automatic mode, manual mode or filling lockout can be selected using. The filling function is managed independently, meaning it does not depend on the control unit's operation mode. It is possible to enable filling either when the genset is powered or when the user is powered. A contact float controls the maximum safety level. Another float with variable resistance (terminal 37) manages activation and deactivation of the output for pump and/or solenoid valve piloting. If the function is enabled by default, the pump relay piloting output is associated to terminal 70, while the maximum level float input is associated to terminal 41.

To change the filling management operation mode, simply press the UP arrow button. The mode is saved in the control unit even if the battery gets disconnected.

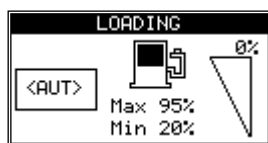

Automatic filling: when the level of fuel drops below the "minimum level", the output is enabled and MINIMUM FUEL LEVEL appears on the display. When the "maximum level" is exceeded, the output is disabled and MAXIMUM FUEL LEVEL appears on the display.

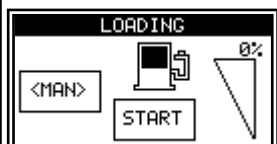

Manual filling: pressing the DOWN ARROW button activates the filling output; taking the finger off the button disables the output.



Filling OFF: turns filling off; the output, if enabled, is disabled.

Request the connection diagram, which can also be downloaded from the website www.elcos.it.

FICTITIOUS LOAD MANAGEMENT

This allows inserting a minimum load when the power absorbed by the power user does not exceed the threshold. When the function is enabled and with the engine running and normal electrical parameters, the “fictitious load” output and, where required by the mode, the genset’s contactor, are activated simultaneously. Fictitious load remains on as long as the power absorbed by the power user does not exceed the off threshold. When the power exceeds the threshold, fictitious load is disabled. It will be enabled once again when the user power drops below the activation threshold. Request the connection diagram, which can also be downloaded from the website www.elcos.it

IMMINENT START WARNING

With the exception of start-ups due to power failure or closing of a call contact, every automatic start-up is preceded by the intermittent activation of the general alarm output for 8 seconds; then, 3 seconds later, the start-up cycle begins. If a buzzer is connected to this output, the operator is notified that start-up is imminent. This function can be bypassed. Warning: the output can be associated to other functions; see the programming manual.

PASSWORD

Access to technical settings is password activated. There are 7 password levels, each level gives access to different settings. The default password settings are all “0000” and it is possible to enter the settings without entering any other codes, except for level 7. To change the codes and activate the passwords, see the programming manual. The list of the 7 levels is given below:

1. The operator can read all the settings but cannot edit them.
2. Access in editing mode to rental hours and history log from maintenance hours.
3. Access only for resetting expired maintenance.
4. Access only for resetting expired rental blocks and for GSM block.
5. The operator can read and edit all settings.
6. Access in editing mode to total operating hours.
7. Access to the device menu.

For example: if we wish to prevent the operator from modifying the total operating hours, we must set a different password to “0000” in level 6, for example “1234”. Doing this, we can enter the technical settings using the default password (“0000”), but will not have access to the operating hours. To access the operating hours menu we must enter the password “1234”.

SERIAL NUMBER (ID)

It is possible to programme an alphanumeric serial code in the control unit. This number is displayed every time the control unit is switched on; it can be read in the INFORMATION menu or by pressing the left arrow for 4 seconds. Refer to the programming manual.









SERIAL PORTS

The control unit has 4 serial ports: RS232, RS485, USB 2.0 and CAN Bus.



- RS232: used to connect the control unit:
 - to a personal computer, for setting parameters with the ZW-100-PR software
 - to a personal computer for the ZW-100 remote operation software
 - to Ethernet interface with the ZW-100 remote operation software
 - to GSM modem for text message management.
- RS485: used to communicate with:
 - input/output expansion modules
 - the remote panel
 - this port can be used in slave mode so that an external device can poll the control unit using the MOD Bus RTU protocol.
- USB 2.0: used to connect the control unit:
 - to a personal computer, for setting parameters with the ZW-100-PR software
 - to a personal computer for the ZW-100 remote operation software.
- CAN Bus: used to connect the control unit to the CAN Bus line of electronic engines with SAE J1939 protocol.

SIGNAL LAMPS FOR HATZ STAGE V ENGINES

The LAMPS instrument group shows the warnings sent by the engine ECU. The messages are accompanied by graphic symbols. The lamps stay on until the ECU stops signalling the warning.



Symbol	Flash	Signal
	Steady	Engine running
	Steady	Service delay
	Steady	Pre-glow active
	Steady	Low oil pressure
	Steady	Engine diagnostic
	Steady	Engine over temperature
	Steady	Air filter switch
	Steady	Alternator status

The LAMPS instrument group also supplies the DPF statuses,

Symbol	Signal	Led	Flash
	DYNAMIC regeneration ongoing	DPF_LED	Slow
	DPF clogging level 1	DPF_LED	Steady
	DPF clogging level 2	DPF_LED	Steady
	Regeneration Inhibited by ECU.		
	Exhaust system temperature too high.		

ECU READINGS

As well as those previously specified in the section "ECU READINGS", the following measurements are available for HATZ Stage V engines.

Symbol	Parameter	SOURCE	UM
	EXHAUST GAS TEMP	ECU: spn 173	°C/°F
	CATALYST TEMPERATURE	ECU: spn 4765	°C/°F
	DPF INTAKE TEMP.	ECU: spn 3242	°C/°F

MANAGEMENT OF EMISSIONS REDUCTION DEVICES

The control unit supports the emissions reduction system for HATZ H50TICD engines.

DPF regeneration operations can be handled on the control unit panel and you have the option to see the related information.

The REGENERATION instrument group allows you to monitor, activate and interrupt STANDBY generation. When regeneration is in progress, the soot level is displayed.



There are two DPF regeneration modes:

- **DYNAMIC REGENERATION**
This is set off automatically and periodically by the engine ECU and ends only when conditions are suitable (temperature at the exhaust, engine speed, etc.) for a sufficient period of time. If DYNAMIC regeneration is in progress, the high temperature at exhaust signal may be displayed on the LAMPS instruments.
- **STANDBY REGENERATION**
A steady-on DPF_LED and the corresponding DPF_LAMP indicate STANDBY regeneration request. To start and stop the regeneration, go to the REGENERATION tool and hold down the ACK_BUTTON. It is possible to interrupt the regeneration in progress by pressing the ACK_BUTTON again. It is possible to start a STANDBY regeneration even if a DYNAMIC regeneration is already in progress. In this case, the latter will be interrupted.
DPF_LED: flashes during the entire DPF STANDBY regeneration phase.

HOURS TO NEXT SERVICE COUNTER

For HATZ H50TICD engines only, the "COUNTERS" group contains the tool HOURS TO NEXT SERVICE.

The tool is visible with the panel on, and shows the countdown of hours remaining until the next "SERVICE". When the counter reaches zero, the Service delay lamp comes on.

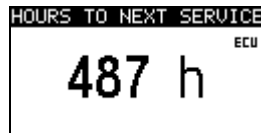

When the "SERVICE" is performed, the maintenance technician will reset the counter to the initial value (500 h).

FOR PROTECTION OF THE ELECTRICAL EQUIPMENT AT BATTERY VOLTAGE AGAINST OVERCURRENTS, REFER TO STANDARDS IEC 44-5 (EN 60204)

POWER USER

CABLES FOR CONNECTION OF CURRENT	
LENGTH m	SECTION sq.m
1	1,5
2	2,5
3	4

MAINS INPUT

GENSET INPUT

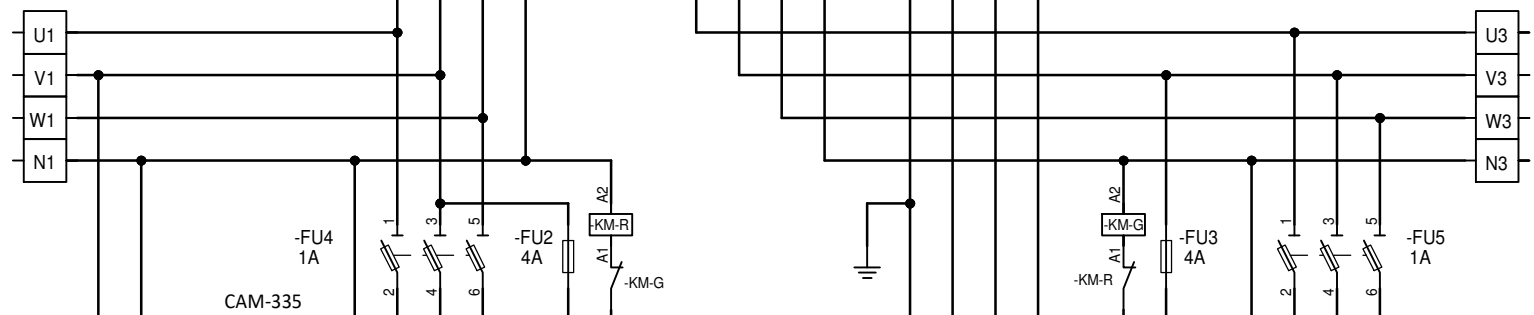

CAM-335-10

TERMINALS: 90, 91, 92, 93 (Mains Input); 71, 72 (Command Contactor Mains); 75, 76, 77, 78 (Meters); 73, 74 (Input Genset); 95, 96, 97, 98 (Command Three-Phase); 99 (Command Two-Phase); 95, 97 (Genset Single-Phase).

MAX 275VAC 3A

CAM-335-10

TERMINALS: 1 (Power +), 2 (Power -), 4 (Signal Emergency Input), 4A (Power Emergency Input), 5 (Analog - Power Supply), 6 (Glow Plug Out), 15 (Start-Up Output), 17 (Stop Output), 19 (Out 15/54), 30 (Call Input), 32 (External Mains Detector), 33 (Start-Up Input), 37 (Fuel Level Input), 41 (Available Input 1), 42 (Available Input 2), 50 (Radiator Fluid Input), 51 (Oil Pressure Input), 52 (Engine Thermostat Input), 57 (Pressure Transmitter Input), 58 (Temperature Transmitter Input), 65 (Tachometer Input), 66 (Exciter Diode Input D+), 70 (Alarm Out).

RS-232, CAN H, CAN L, USB

SAE J1939

RS-485 +, RS-485 -, RS-485 GND

(*) PROGRAMMABLE

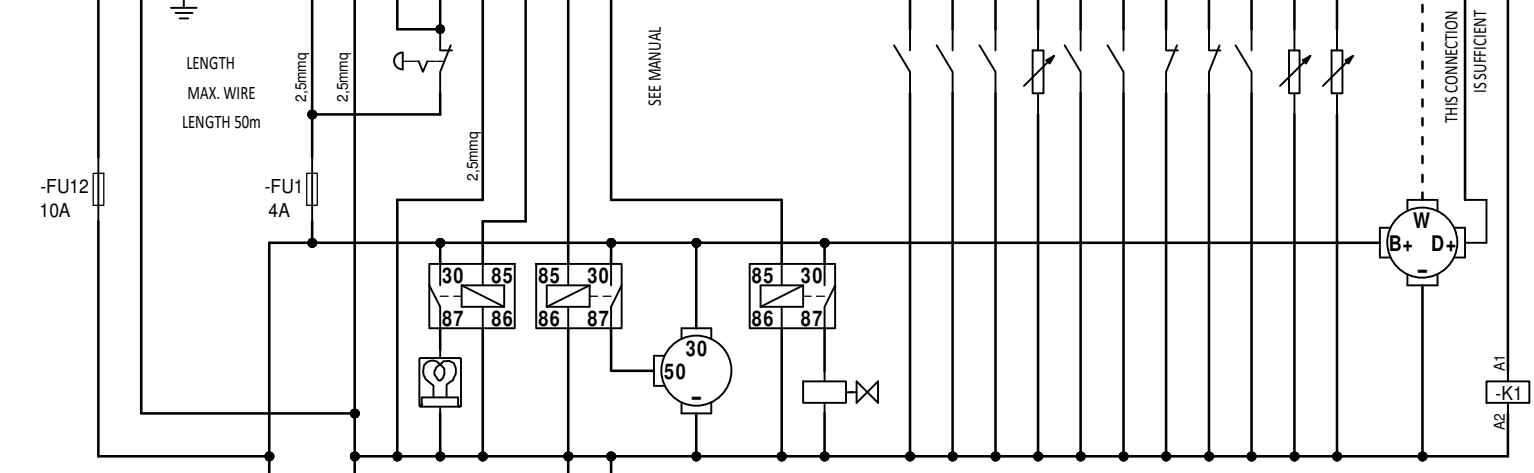

DO NOT INSTALL THE EMERGENCY BUTTON COMBINED WITH A STOP SYSTEM WHICH IS NOT ENERGIZED WHILE THE ENGINE IS RUNNING

Detail of connection of the control unit to a permanent magnet battery charger alternator. For different controllers, request diagram.

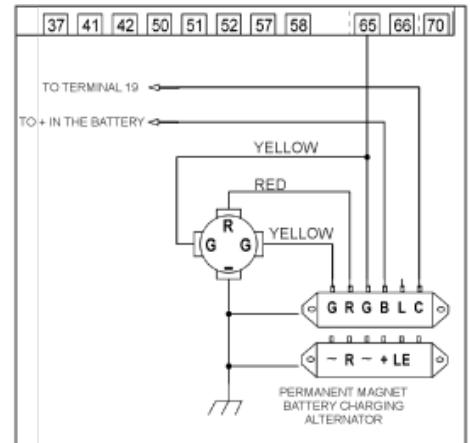

Detail of connection of the control unit to an electronic engine via CAN Bus. Use an insulated twisted-wire cable not longer than 40 metres. For additional details, request the diagrams for the specific engines.

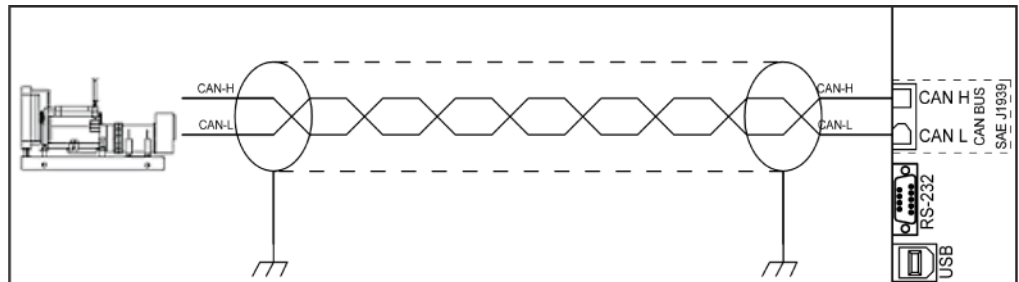

In the manual for the control unit (ECU/ECM), read if inserting the 120ohm 1/4W termination resistor, engine side, between the CAN-H and CAN-L wires is required.

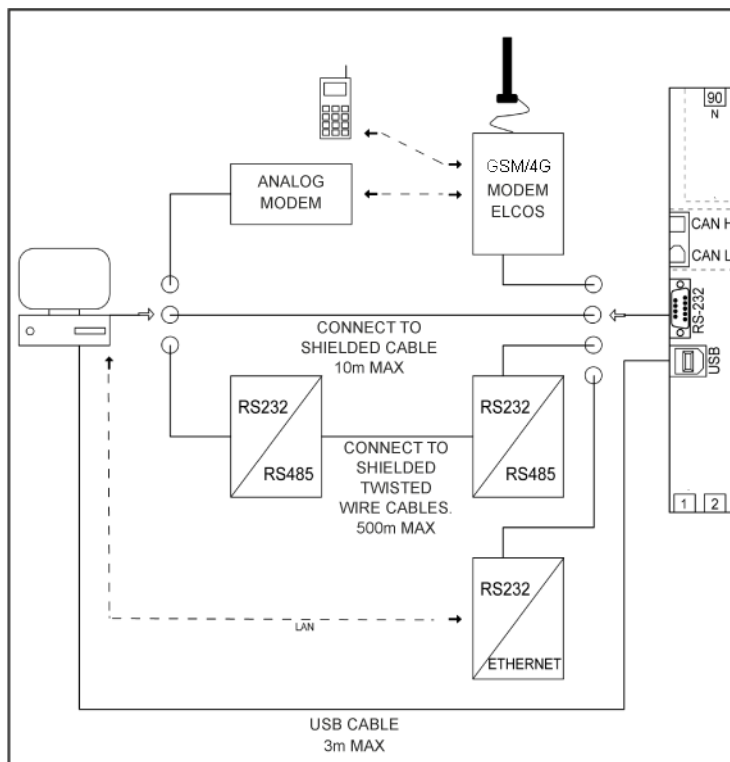

The above diagram indicates the different types of connections for the RS232 port.

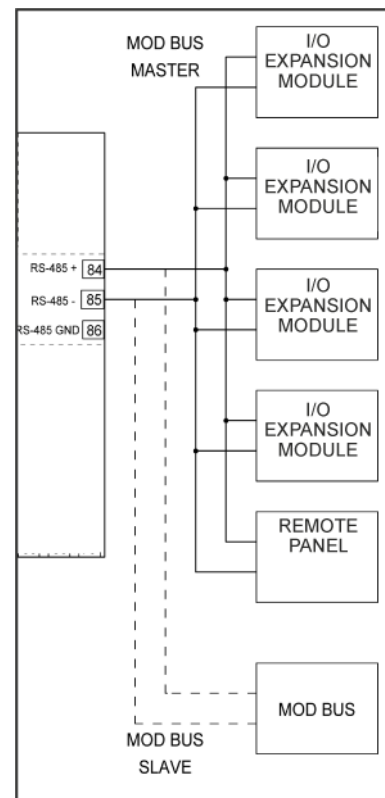

The RS485 serial port can act as a master to manage expansions and / or time synchronization of other control units, horaire, as a slave to be polled by external devices.

Once the connections have been made and powered, the control unit is set to OFF. See programming to change this status.



USER PROGRAMMING

To access user programming, press the FUNCTION  key and keep it pressed until "PROG" appears on the display.





Release the button. After a few seconds

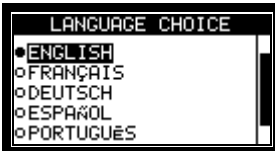

Press the   arrows to scroll through the programming menus. Press  to enter the desired sub-menu. For example:



Press   to scroll through the programming items. For example:

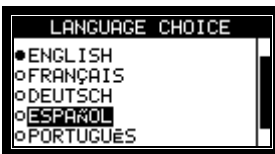

Press  to confirm the selection. The following appears:

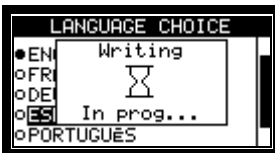

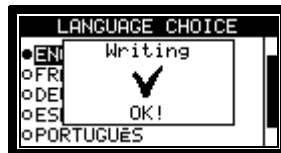

Wait for a few seconds:





The chosen parameter is now programmed in the control unit. The settings are stored in a non-volatile memory, and are therefore maintained even if the power is switched off. The value can be modified at any time by repeating the procedure as described above.

Press  to return to the previous menu and then proceed to program the other parameters.

Programming a numerical parameter.

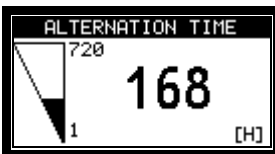
When programming a numerical parameter, such as a threshold or a time, press   to increase or decrease the parameter.



Press  to confirm the value. When the number is saved in the control unit, it changes colour.



Enabling/disabling a parameter.

When programming a binary parameter (enabled/disabled), for example, enabling the weekly automatic test, press



to enable or disable the parameter. For example:



or



Press  to confirm the value.

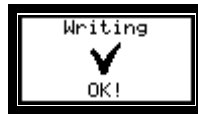

Programming a number.

When programming a numerical code such as, for example, telephone numbers for the GSM modem, press



to edit the number indicated by the cursor. For example:

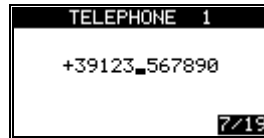
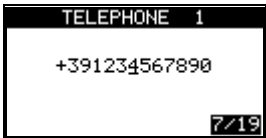

Press   to move the cursor

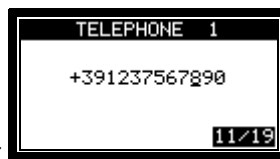

Confirm the programming by pressing .

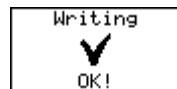

User-programmable parameters are:

<i>Parameter</i>	<i>Range</i>		<i>Default setting</i>	<i>Notes</i>
LANGUAGE CHOICE	ITALIAN		ITALIAN	A CUSTOM language cannot be selected unless the messages have been programmed with the software ZW-100-PR.
	ENGLISH			
	FRENCH			
	GERMAN			
	SPANISH			
	PORTUGUESE			
	CUSTOM			
CLOCK/CALENDAR	Standard			Calendar clock adjustment.
TELEPHONE NUMBERS	TELEPHONE 1	16 digits	Empty	Telephone numbers to which text messages will be sent with the GSM modem.
	TELEPHONE 2	16 digits	Empty	
	TELEPHONE 3	16 digits	Empty	
WEEKLY TEST	OFF		OFF	
	ENGAGED			
DAILY START	START 1	00:00 + 23:59	--:-- + --:--	With --:-- + --:-- starting is off.
	START 2	00:00 + 23:59	--:-- + --:--	
	START 3	00:00 + 23:59	--:-- + --:--	
	START 4	00:00 + 23:59	--:-- + --:--	
	START 5	00:00 + 23:59	--:-- + --:--	
	START 6	00:00 + 23:59	--:-- + --:--	
	START 7	00:00 + 23:59	--:-- + --:--	
	START 8	00:00 + 23:59	--:-- + --:--	
	START 9	00:00 + 23:59	--:-- + --:--	
	START 10	00:00 + 23:59	--:-- + --:--	
DAILY STOP	00:00 + 23:59		--:-- + --:--	With --:-- + --:-- stopping is off.

FAULT LIST

The complete list of anomalies managed by the control unit is given below.

Fault code	Description	Occurs when:
111	MAINTENANCE 1	Maintenance 1 expired.
112	MAINTENANCE 2	Maintenance 2 expired.
113	MAINTENANCE 3	Maintenance 3 expired.
114	PROGRAMMED MAINTENANCE	Programmed maintenance expired.
115	RENTAL HOURS	The rental hours have expired.
120	BATTERY UNDERVOLTAGE	The battery voltage is lower than the set threshold.
121	BATTERY OVERVOLTAGE	The battery voltage is higher than the set threshold.
122	ENGINE LOW TEMPERATURE	The engine has not reached the set temperature.
123	OVERTEMPERATURE PRE-ALARM	The engine has exceeded the overtemperature pre-alarm threshold.
124	PRE-ALARM	The engine has exceeded the overtemperature threshold read by the transmitter.
125	THERMOSTAT OVERTEMPERATURE	The engine thermostat has cut in.
126	MAXIMUM FUEL LEVEL	The maximum top-up level contact float has cut in.
129	FUEL RESERVE	The fuel level is lower than the reserve threshold.
130	NO FUEL	The fuel level is lower than the set threshold.
131	LOW OIL PRESSURE PRE-ALARM	The engine oil pressure does not exceed the set threshold.
132	LOW OIL PRESSURE	The engine oil pressure switch has cut in.
133	STOPPING FAILURE	Detects that engine is running even if the stopping system has been activated.
135	LOW RADIATOR LEVEL	Insufficient radiator coolant.
136	CHARGING ALTERNATOR	The output "D+" or "W" on the charging alternator does not work.
137	STARTING FAILURE	The control unit has attempted to start the generator, but the engine is not running.
139	OVERSPEED	The RPMs detected by the control unit have exceeded the set threshold.
140	FUEL FLOAT INTERRUPTED	The electrical circuit for the fuel float is interrupted.
141	OIL PRESSURE SWITCH ANOMALY	The oil pressure switch contact is open with the engine switched off.
220	GENERATOR UNDERVOLTAGE	The genset voltage is lower than the set threshold.
221	GENERATOR OVERPOWER	The power absorbed by the generator has exceeded the alarm threshold.
222	GENERATOR OVERVOLTAGE	The genset voltage is higher than the set threshold.
223	GENERATOR UNDERFREQUENCY	The genset Hz value is lower than the set threshold.
224	GENERATOR OVERFREQUENCY	The genset Hz value is higher than the set threshold.
225	GENERATOR OVERLOAD PRE-ALARM	The current absorbed by the genset has exceeded the pre-alarm threshold.
226	GENERATOR OVERLOAD	The current absorbed by the genset has exceeded the alarm threshold.
227	GENERATOR NOT DELIVERING	Although running, the genset does not deliver voltage.
228	GENERATOR CONTACTOR FAULT	The generator contactor does not open or close.
230	GENERATOR PHASE SEQUENCE	The sequence of the three genset phases is not correct.
231	GENERATOR ASYMMETRY	The voltages between the three genset phases are not similar.
322	MAINS CONTACTOR FAULT	The mains contactor does not open or close.
323	MAINS PHASE SEQUENCE	The sequence of the three mains phases is not correct.
325	MAINS OVERLOAD	The current absorbed by the mains has exceeded the alarm threshold.
419	EMERGENCY STOP	The emergency button has been pressed.
421	AVAILABLE ANOMALY 41	The anomaly associated with programmable input 41 has occurred.
422	AVAILABLE ANOMALY 42	The anomaly associated with programmable input 42 has occurred.
426	AVAILABLE ANOMALY 32	The anomaly associated with programmable input 32 has occurred.
427	AVAILABLE ANOMALY 33	The anomaly associated with programmable input 33 has occurred.
430	CAN BUS	The control unit does not receive data from the CAN Bus line.
431	ENGINE CONTROL UNIT	Engine fault detected by the electronic control unit (ECU).
443	FUEL FLOAT TABLE ERROR	The float table has been programmed with errors.
446	OIL PRESSURE TRANSMITTER TABLE ERROR	The oil pressure transmitter table has been programmed with errors.
447	TEMPERATURE TRANSMITTER TABLE ERROR	The temperature transmitter table has been programmed with errors.
449	KEYBOARD ERROR	The control unit turns on with at least one button pressed.
500	NO GSM MODEM	The GSM modem does not communicate with the control unit.
501	SIM NOT INSTALLED	There is no SIM card installed in the GSM modem.
502	SIM BLOCKED	The PIN code of the SIM Card installed in the modem is active.
503	GSM CODE ERROR	The GSM modem has detected a coded error.
504	GENERIC GSM ERROR	The GSM modem has detected a non-coded error.
505	NO REMOTE PANEL COMMUNICATION	The remote panel does not respond to the control unit data request.
506	I/O EXP. 1 FAULT	The input/output expansion module does not respond to the data request.
507	I/O EXP. 2 FAULT	The input/output expansion module does not respond to the data request.
508	I/O EXP. 3 FAULT	The input/output expansion module does not respond to the data request.
509	I/O EXP. 4 FAULT	The input/output expansion module does not respond to the data request.
510	RTCK SYBCHR.1 FAILED	RTCK synchronization of control unit 1 failed.
511	RTCK SYBCHR.2 FAILED	RTCK synchronization of control unit 2 failed.
512	RTCK SYBCHR.3 FAILED	RTCK synchronization of control unit 3 failed.
513	RTCK SYBCHR.4 FAILED	RTCK synchronization of control unit 4 failed.
556	BLOCK VIA GSM	The control unit is blocked by a text message command.
-	MDE-088 [01 – 32]	The error associated to I/O module programmable input has occurred.
-	EEPROM ERROR	Failed access to the static memory.

TECHNICAL SPECIFICATIONS

Power supply			
Suitable for batteries		12Vdc	24Vdc
Operating range		8 ÷ 48Vdc	
Absorption with engine not running		130mA to 12Vdc	90mA to 24Vdc
Voltage dip on battery power supply		From 10Vdc to 0Vdc for 20ms	
Digital inputs			
Type of input		Negative	
Maximum current supplied		0.30mA	
Voltage threshold for low signal		≤ 0.2Vdc	
Voltage threshold for high signal		≥ 2Vdc	
Terminal input 65			
AC voltage		5.5 ÷ 65Vac	
Measurement range		50 - 1500Hz	
Mains and generator voltmetric inputs			
Dielectric strength voltage between battery voltage circuits and mains/generator voltage circuits		3750Vac 50Hz 1sec	
Rated insulation voltage	Mains voltage terminal	600Vac	
	Genset voltage terminal	600Vac	
	Battery voltage terminal	48Vac	
Insulation class		1	
Measurement range		80 ÷ 570Vac (three-phase)	45 ÷ 340Vac (single-phase)
Accuracy		±1%	
Frequency meter			
Measurement range		45 - 85Hz	
Accuracy		±0.1Hz	
Amperometric inputs			
Measurement range		20mA ÷ 6Aac	
Amperometric transformer ratio		/5	
Maximum displayable current		4800Aac	
Accuracy		±1%	
Digital outputs			
Type of output		Positive (battery voltage)	
Maximum load	Terminal 6, 15, 19, 70.	0.25 A	
	Terminal 17	1.5 A	
Contactors command outputs			
Type of output		Dry contact	
Maximum applicable voltage		275Vac	
Maximum load		3 A	
Displayed powers (kW, kVAR, kVA, kWh)			
Accuracy		±2%	
Engine instruments			
Oil pressure	0 ÷ 360Ohm	0.0 ÷ 9.0BAR	0 ÷ 900kPa
Temperature	0 ÷ 3000Ohm	0 ÷ 140°C	0 ÷ 284°F
Fuel level	0 ÷ 360Ohm	0 ÷ 100%	
Accuracy (pressure gauge, thermometer, fuel level)		±2%	
Lines of communication			
RS232 (No optoisolator)	Baud-rate	1200 ÷ 115200 bps	
	Parity	None/even	
RS485 (No optoisolator)	Baud-rate	1200 ÷ 115200 bps	
	Parity	None/even	
USB 2.0 (Micro USB-B)	Interface	Not isolated. Maximum cable length 3 m.	
CAN Bus (No optoisolator)	Baud-rate	250kbps	
	Protocol	SAE J1939	
Environmental conditions			
Operating temperature		-20 ÷ 60°C	
Storage temperature		-20 ÷ 60°C	
Relative humidity		≤ 80%	
Vibration resistance		1g on the 3 axes (CEI EN 60068-2-6)	
Impact resistance		15 on the 3 axes (CEI EN 60068-2-27)	
Protection class			
Back		IP 20	
Front		IP 64	
Container			
Weight		480g	
Dimensions (LxHxW)		157x109x74mm	
Perforations		137x88 mm	
Material		PC/ABS V0	

WARNING

Performs only genset control and command functions. It controls the mains and generator contactors for user power supply. It is designed solely to be built into an electrical panel and connected to the other components (contactors, fuses, thermal magnetic switches, etc.) the installer has arranged to complete the system.



Attention: Parts powered with dangerous voltages

The control unit can only be accessed by specifically assigned, duly trained personnel. Maintenance operations cannot be performed unless the system is disconnected from the mains and the battery. As an additional protection measure, we recommend grounding the system phases.

Notwithstanding the above, only specifically assigned, duly trained personnel can perform the following operations with the system powered:

- visual inspection of control unit connections and markings;
- taking voltage and/or current measurements;
- function programming.

These works must always be performed using equipment that ensures appropriate electrical protection.



Warning: Compliance with the following recommendations is obligatory

- Always make connections following the wiring diagram shown on page 12-13.
- All works performed on the unit must be carried out with the engine off and with starter motor terminal 50 disconnected.
- Check the consumption of the connected devices is in line with the described technical specifications.
- The installation must always guarantee adequate dissipation of heat.
- Always install the device at a lower position than any other devices that produce or dissipate heat.
- Handle and connect without exposing the electronic circuit board to mechanical strain.
- Do not let cuttings of copper conductors or other metal residues drop onto the control unit.
- Never disconnect the battery terminals while the engine is running.
- Strictly avoid using a battery charger for emergency start-up; this could damage the control unit.
- To safeguard persons and equipment, always disconnect the electrical system terminals from the battery poles before connecting an external battery charger.

THIS UNIT IS NOT SUITABLE FOR WORKING UNDER CONDITIONS WHERE:

- The room temperatures exceeds the limits specified in the technical data sheet.
- Abrupt shifts in temperature and air pressure produce exceptional condensation.
- There is high pollution caused by dust, fumes, vapour, salts and corrosive or radioactive particles.
- There is high radiation of heat due to direct sunlight, ovens or the like.
- You suspect the presence of mould or pests.
- There is a danger of fire or explosion.
- Strong shocks or vibrations can be transmitted to the control unit.
- The control unit is protected by barriers or casings with a protection rating below IP40.

ELECTROMAGNETIC COMPATIBILITY

This control unit works correctly only if it is installed in systems that comply with regulations governing CE or UKCA marking; in fact, it complies with the immunity requirements given in EN61326-1, but this does not rule out the possibility that malfunctions could occur in extreme cases that may arise in particular situations.

The installer is responsible for checking that the level of perturbation does not exceed that specified in standards.

OPERATION AND MAINTENANCE

We recommend the following maintenance on a weekly basis:

- signal operation checks;
- battery status checks;
- conductor tightness and terminal status checks.

YOUR ELECTRICIAN MAY TELEPHONE OUR TECHNICAL SERVICE WITH ANY QUESTIONS REGARDING
THIS CONTROL UNIT

INFORMATION FOR ORDERING

Type
CAM-335-10

Item Code
00242265

STANDARD ACCESSORIES

Type
KIT MU CAM-335

Item Code
40804479

ACCESSORIES AVAILABLE ON REQUEST

Type
EXPANSION MODULE MDE-088
ETHERNET INTERFACE ZE-100
GSM MODEM AMD-RB900 PRO

Item Code
00242269
00070227
00070218

Programming software ZW-SMART

00070212

DOCUMENTATION ON REQUEST

Downloadable from the website www.elcos.it/

Petrol engine diagram
Automatic fuel filling diagram
Fictitious load diagram
Connection diagram with expansion modules
Connection diagram with voltage transformers
Connection diagram with contact float

Diagram
number
00000731
00000732
00000733
00000734
00000735
00000736

List of MOD Bus CAM-335-10 addresses

DECLARATION OF CONFORMITY

